

Wheels and castors with polyurethane tread

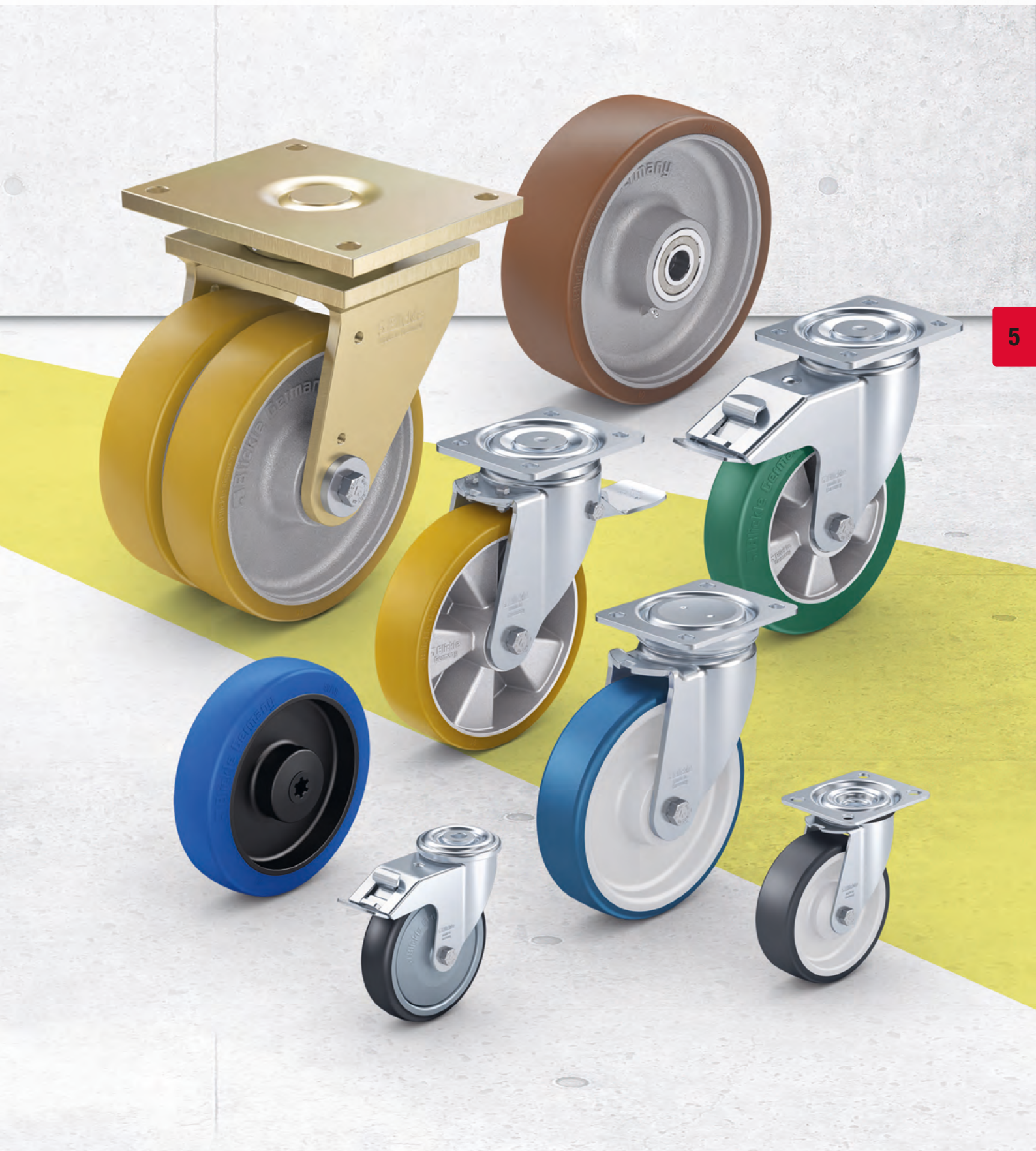

5

Selection tool

Wheels and castors with polyurethane tread



Series	PATH	POTH	POTHS	ALTH	SETH	VSTH / GTH
Category	Standard polyurethane					
Tread / tyre	Thermoplastic polyurethane (TPU)			Polyurethane elastomer Blickle Extrathane®		
Tread and tyre hardness	94 Shore A	94 Shore A	80 Shore A	92 Shore A	92 Shore A	92 Shore A
Electrical conductivity	optional	–	–	optional	–	optional
Wheel centre / rim	nylon	nylon	nylon	aluminium	thick-walled pressed steel	VSTH: steel GTH: grey cast iron
Wheel Ø	80–200 mm	75–250 mm	100–200 mm	80–250 mm	125–250 mm	35–1,000 mm
Load capacity up to	500 kg	1,000 kg	550 kg	1,250 kg	1,350 kg	30,000 kg
Rolling resistance	■ ■ ■ ■ ■	■ ■ ■ ■ ■	■ ■ ■ ■ ■	■ ■ ■ ■ ■	■ ■ ■ ■ ■	■ ■ ■ ■ ■
Smooth operation and floor preservation	■ ■ ■ ■ ■	■ ■ ■ ■ ■	■ ■ ■ ■ ■	■ ■ ■ ■ ■	■ ■ ■ ■ ■	■ ■ ■ ■ ■
Speeds up to	4 km/h	4 km/h	4 km/h	10 km/h	10 km/h	10 km/h
Use in wet areas	(✓)	(✓)	✓	–	–	–
For a description of the wheel, refer to	page 258	page 263	page 270	page 274	page 282	page 286–287
For information about swivel and fixed castors, refer to	page 259–262	page 264–269	page 271–273	page 275–281	page 283–285	page 288–293

■ ■ ■ ■ ■ excellent

■ ■ ■ ■ ■ very good

■ ■ ■ ■ ■ good

■ ■ ■ ■ ■ satisfactory

■ ■ ■ ■ ■ sufficient

✓ yes – no



ALST	GST	ALB	VSB / GB	POBS	ALBS	GVU
Standard polyurethane		Premium polyurethane				
Polyurethane elastomer Blickle Softhane®		Polyurethane elastomer Blickle Besthane®		Polyurethane elastomer Blickle Besthane® Soft		Vulkollan®
75 Shore A	75 Shore A	92 Shore A	92 Shore A	75 Shore A	75 Shore A	92 Shore A
optional	optional	–	optional	–	–	–
aluminium	grey cast iron	aluminium	VSB: steel GB: grey cast iron	nylon	aluminium	grey cast iron
80–300 mm	125–400 mm	100–250 mm	80–1,000 mm	80–200 mm	80–300 mm	100–400 mm
1,150 kg	3,000 kg	1,250 kg	30,000 kg	500 kg	1,150 kg	3,000 kg
■ ■ ■ ■ ■	■ ■ ■ ■ ■	■ ■ ■ ■ ■	■ ■ ■ ■ ■	■ ■ ■ ■ ■	■ ■ ■ ■ ■	■ ■ ■ ■ ■
■ ■ ■ ■ ■	■ ■ ■ ■ ■	■ ■ ■ ■ ■	■ ■ ■ ■ ■	■ ■ ■ ■ ■	■ ■ ■ ■ ■	■ ■ ■ ■ ■
10 km/h	10 km/h	16 km/h	16 km/h	4 km/h	16 km/h	16 km/h
–	–	–	–	✓	–	–
page 294	page 301	page 307	page 312–313	page 318	page 319	page 326
page 295–300	page 302–306	page 308–311	page 314–317	–	page 320–325	–

5

PATH series

Wheels with thermoplastic polyurethane tread,
with nylon wheel centre

150–500 kg

Tread and tyre hardness

94 Shore A

Smooth operation / floor preservation

good

Rolling resistance

very good

Wear resistance

very good

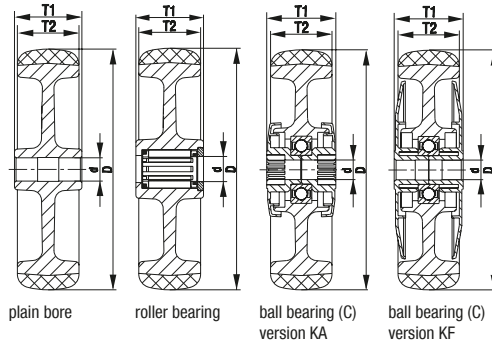

Tread:

- high-quality thermoplastic polyurethane (TPU), hardness 94 Shore A
- low rolling and swivel resistance
- high abrasion resistance
- colour dark grey, non-marking, non-staining
- chemically-bonded inseparable connection with the wheel centre

Wheel centre:

- high-quality nylon 6, impact resistant
- colour silver grey

Other features:

- KA version: with synthetic thread guard, small
- KF version: with synthetic thread guard, large
- very high chemical resistance to many aggressive substances
- operating temperature: -20 °C to +70 °C, temporarily up to +90 °C, reduced load capacity over +35 °C

Additional details:

- wheel series: page 61
- tread: page 55
- bearing types: page 84–85
- chemical resistance: page 51

Wheels	Wheel Ø (D) [mm]	Wheel width (T2) [mm]	Load capacity [kg]	Bearing type	Axle bore Ø (d) [mm]	Hub length (T1) [mm]
PATH 80/12G	80	32	150	plain bore	12	35
PATH 80/8KF	80	32	150	ball bearing (C)	8	36
PATH 100/12G	100	32	200	plain bore	12	45
PATH 100/8KF	100	32	200	ball bearing (C)	8	46
PATH 100/10KF	100	32	200	ball bearing (C)	10	46
PATH 125/12G	125	32	250	plain bore	12	45
PATH 125/8KF	125	32	250	ball bearing (C)	8	46
PATH 125/10KF	125	32	250	ball bearing (C)	10	46
PATH 160/20G	160	40	400	plain bore	20	60
PATH 160/20R	160	40	400	roller bearing	20	60
PATH 160/12KA	160	40	400	ball bearing (C)	12	62
PATH 160/20KA	160	40	400	ball bearing (C)	20	60
PATH 200/20G	200	40	500	plain bore	20	60
PATH 200/20R	200	40	500	roller bearing	20	60
PATH 200/12KA	200	40	500	ball bearing (C)	12	62
PATH 200/20KA	200	40	500	ball bearing (C)	20	60

For other dimensions, see page 136

Versions / options



	plain bore version	electrically conductive version, non-marking grey	small thread guard with additional ball bearing seal	large thread guard with additional ball bearing seals
Technical description page		50	85	85
Product code suffix		-ELS	-KAD	-KFD
Available for		all ball bearing versions*	all KA versions	all KF versions

* Wheel load capacity of electrically conductive version reduced by 35%

LE-PATH, B-PATH series

Pressed steel castors with top plate,
wheel with thermoplastic
polyurethane tread

150–300 kg



Bracket: LE/B series

- pressed steel, zinc-plated, blue-passivated, Cr6-free

Swivel bracket:

- double ball bearing in the swivel head
- swivel head seal
- minimum swivel head play and smooth rolling characteristic and increased service life due to the special dynamic Blickle riveting process

Wheel: PATH series

- tread: high-quality thermoplastic polyurethane (TPU), hardness 94 Shore A, colour dark grey, non-marking, non-staining
- wheel centre: high-quality nylon 6, impact resistant, colour silver grey

Additional details:

- bracket series: page 90
- brakes: page 112–113
- wheel series: page 258
- bearing types: page 84–85

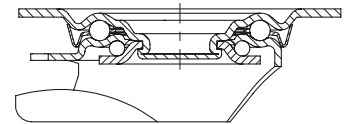

5

Swivel castors	Fixed castors	Swivel castors with "stop-fix" brake	Wheel Ø [mm]	Wheel width [mm]	Load capacity [kg]	Bearing type	Total height [mm]	Plate size [mm]	Bolt hole spacing [mm]	Bolt hole Ø [mm]	Offset swivel castor [mm]
LE-PATH 80G	B-PATH 80G	LE-PATH 80G-FI	80	32	150	plain bore	102	100 x 85	80 x 60	9	38
LE-PATH 80KF	B-PATH 80KF	LE-PATH 80KF-FI	80	32	150	ball bearing (C)	102	100 x 85	80 x 60	9	38
LE-PATH 100G	B-PATH 100G	LE-PATH 100G-FI	100	32	150	plain bore	125	100 x 85	80 x 60	9	36
LE-PATH 100KF	B-PATH 100KF	LE-PATH 100KF-FI	100	32	150	ball bearing (C)	125	100 x 85	80 x 60	9	36
LE-PATH 125G	B-PATH 125G	LE-PATH 125G-FI	125	32	150	plain bore	150	100 x 85	80 x 60	9	38
LE-PATH 125KF	B-PATH 125KF	LE-PATH 125KF-FI	125	32	150	ball bearing (C)	150	100 x 85	80 x 60	9	38
LE-PATH 160G	B-PATH 160G	LE-PATH 160G-FI	160	40	300	plain bore	195	140 x 110	105 x 75–80	11	54
LE-PATH 160R	B-PATH 160R	LE-PATH 160R-FI	160	40	300	roller bearing	195	140 x 110	105 x 75–80	11	54
LE-PATH 160KA	B-PATH 160KA	LE-PATH 160KA-FI	160	40	300	ball bearing (C)	195	140 x 110	105 x 75–80	11	54
LE-PATH 200G	B-PATH 200G	LE-PATH 200G-FI	200	40	300	plain bore	235	140 x 110	105 x 75–80	11	54
LE-PATH 200R	B-PATH 200R	LE-PATH 200R-FI	200	40	300	roller bearing	235	140 x 110	105 x 75–80	11	54
LE-PATH 200KA	B-PATH 200KA	LE-PATH 200KA-FI	200	40	300	ball bearing (C)	235	140 x 110	105 x 75–80	11	54

For stainless steel versions, see page 407

Versions / options



	plain bore version	electrically conductive version, non-marking grey	with "stop-top" brake	directional lock (separate) 1 x 360°	small thread guard with additional ball bearing seal	large thread guard with additional ball bearing seals
Technical description page		50	112	115	85	85
Product code suffix		-ELS	-ST	RI-03.01 / RI-03.03	-KAD	-KFD
Available for		all ball bearing versions*	wheel Ø 160–200 mm	RI-03.01: Ø 100–125 RI-03.03: Ø 160–200 **	upon request	upon request

* Wheel load capacity of electrically conductive version reduced by 35%

** Only for swivel castors without brake or swivel castor with "stop-top" brake upon request

LER-PATH series

**Pressed steel castors with bolt hole,
wheel with thermoplastic
polyurethane tread**



150–300 kg

Bracket: LER series

- pressed steel, zinc-plated, blue-passivated, Cr6-free
- double ball bearing in the swivel head
- strong central kingpin
- minimum swivel head play and smooth rolling characteristic and increased service life due to the special dynamic Blickle riveting process

Wheel: PATH series

- tread: high-quality thermoplastic polyurethane (TPU), hardness 94 Shore A, colour dark grey, non-marking, non-staining
- wheel centre: high-quality nylon 6, impact resistant, colour silver grey

Additional details:

- bracket series: page 91
- brakes: page 112–113
- wheel series: page 258
- bearing types: page 84–85

5

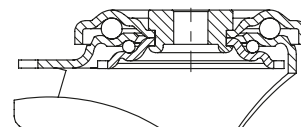

Swivel castors	Swivel castors with "stop-fix" brake	Wheel Ø [mm]	Wheel width [mm]	Load capacity [kg]	Bearing type	Total height [mm]	Plate Ø [mm]	Bolt hole Ø [mm]	Offset swivel castor [mm]
LER-PATH 80G	LER-PATH 80G-FI	80	32	150	plain bore	102	70	13	38
LER-PATH 80KF	LER-PATH 80KF-FI	80	32	150	ball bearing (C)	102	70	13	38
LER-PATH 100G	LER-PATH 100G-FI	100	32	150	plain bore	125	70	13	36
LER-PATH 100KF	LER-PATH 100KF-FI	100	32	150	ball bearing (C)	125	70	13	36
LER-PATH 125G	LER-PATH 125G-FI	125	32	150	plain bore	150	70	13	38
LER-PATH 125KF	LER-PATH 125KF-FI	125	32	150	ball bearing (C)	150	70	13	38
LER-PATH 160G	LER-PATH 160G-FI	160	40	300	plain bore	195	88	13	54
LER-PATH 160R	LER-PATH 160R-FI	160	40	300	roller bearing	195	88	13	54
LER-PATH 160KA	LER-PATH 160KA-FI	160	40	300	ball bearing (C)	195	88	13	54
LER-PATH 200G	LER-PATH 200G-FI	200	40	300	plain bore	235	88	13	54
LER-PATH 200R	LER-PATH 200R-FI	200	40	300	roller bearing	235	88	13	54
LER-PATH 200KA	LER-PATH 200KA-FI	200	40	300	ball bearing (C)	235	88	13	54

For stainless steel versions, see page 408

Versions / options



	plain bore version	electrically conductive version, non-marking grey	small thread guard with additional ball bearing seal	large thread guard with additional ball bearing seals	truck lock
Technical description page		50	85	85	114
Product code suffix		-ELS	-KAD	-KFD	FF 100-1 / FF 125-1
Available for		all ball bearing versions*	upon request	upon request	wheel Ø 100+125 mm

* Wheel load capacity of electrically conductive version reduced by 35%

L-PATH, B-PATH series

Pressed steel castors, medium-duty version, with top plate, wheel with thermoplastic polyurethane tread

150–400 kg

Bracket: L/B series

- pressed steel, zinc-plated, blue-passivated, Cr6-free

Swivel bracket:

- double ball bearing in the swivel head
- strong central kingpin (from wheel Ø 150 mm)
- swivel head seal
- minimum swivel head play and smooth rolling characteristic and increased service life due to the special dynamic Blickle riveting process

Wheel: PATH series

- tread: high-quality thermoplastic polyurethane (TPU), hardness 94 Shore A, colour dark grey, non-marking, non-staining
- wheel centre: high-quality nylon 6, impact resistant, colour silver grey

Additional details:

- bracket series: page 91
- brakes: page 112–113
- wheel series: page 258
- bearing types: page 84–85

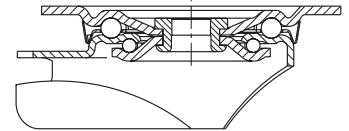

5

Swivel castors	Fixed castors	Swivel castors with "stop-fix" brake	Wheel Ø [mm]	Wheel width [mm]	Load capacity [kg]	Bearing type	Total height [mm]	Plate size [mm]	Bolt hole spacing [mm]	Bolt hole Ø [mm]	Offset swivel castor [mm]
L-PATH 80G	B-PATH 80G	L-PATH 80G-FI	80	32	150	plain bore	102	100 x 85	80 x 60	9	38
L-PATH 80KF	B-PATH 80KF	L-PATH 80KF-FI	80	32	150	ball bearing (C)	102	100 x 85	80 x 60	9	38
L-PATH 100G	B-PATH 100G	L-PATH 100G-FI	100	32	200	plain bore	125	100 x 85	80 x 60	9	36
L-PATH 100KF	B-PATH 100KF	L-PATH 100KF-FI	100	32	200	ball bearing (C)	125	100 x 85	80 x 60	9	36
L-PATH 125G	B-PATH 125G	L-PATH 125G-FI	125	32	250	plain bore	150	100 x 85	80 x 60	9	38
L-PATH 125KF	B-PATH 125KF	L-PATH 125KF-FI	125	32	250	ball bearing (C)	150	100 x 85	80 x 60	9	38
L-PATH 160G	B-PATH 160G	L-PATH 160G-FI	160	40	400	plain bore	195	140 x 110	105 x 75–80	11	60
L-PATH 160R	B-PATH 160R	L-PATH 160R-FI	160	40	400	roller bearing	195	140 x 110	105 x 75–80	11	60
L-PATH 160KA	B-PATH 160KA	L-PATH 160KA-FI	160	40	400	ball bearing (C)	195	140 x 110	105 x 75–80	11	60
L-PATH 200G	B-PATH 200G	L-PATH 200G-FI	200	40	400	plain bore	235	140 x 110	105 x 75–80	11	65
L-PATH 200R	B-PATH 200R	L-PATH 200R-FI	200	40	400	roller bearing	235	140 x 110	105 x 75–80	11	65
L-PATH 200KA	B-PATH 200KA	L-PATH 200KA-FI	200	40	400	ball bearing (C)	235	140 x 110	105 x 75–80	11	65

Versions / options *



	ball bearing version KF	electrically conductive version, non-marking grey	with "stop-top" brake	with "central-stop" central brake system	directional lock (separate) 1 x 360°	with steel foot guard
Technical description page		50	112	113	115	116
Product code suffix		-ELS	-ST	-CS11	RI-03.01 / RI-05.03	-FS
Available for		all ball bearing versions**	all	wheel Ø 160–200 mm	RI-03.01: Ø 100–125 RI-05.03: Ø 160–200 ***	wheel Ø 100–200 mm

* Other versions / options: wheel with additional ball bearing seals (-KAD or -KFD), available upon request (see page 85 for technical information)

** Wheel load capacity of electrically conductive version reduced by 35%

*** Only for swivel castors without brake or swivel castor with "stop-top" and "central-stop" brake upon request

LK-PATH, BK-PATH, BH-PATH series

Pressed steel castors, heavy-duty design, with top plate, wheel with thermoplastic polyurethane tread

150–500 kg

Bracket: LK/BK/BH series

- strong pressed steel, zinc-plated, blue-passivated, Cr6-free

Swivel bracket:

- double ball bearing in the swivel head
- strong central kingpin (from wheel Ø 125x50 mm)
- swivel head seal
- minimum swivel head play and smooth rolling characteristic and increased service life due to the special dynamic Blickle riveting process

Wheel: PATH series

- tread: high-quality thermoplastic polyurethane (TPU), hardness 94 Shore A, colour dark grey, non-marking, non-staining
- wheel centre: high-quality nylon 6, impact resistant, colour silver grey

Additional details:

- bracket series: page 92
- brakes: page 112–113
- wheel series: page 258
- bearing types: page 84–85



5

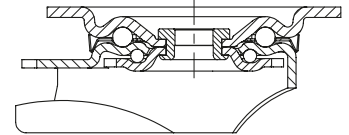

Swivel castors	Fixed castors	Swivel castors with "stop-fix" brake	Wheel Ø [mm]	Wheel width [mm]	Load capacity [kg]	Bearing type	Total height [mm]	Plate size [mm]	Bolt hole spacing [mm]	Bolt hole Ø [mm]	Offset swivel castor [mm]
LK-PATH 80G	BK-PATH 80G	LK-PATH 80G-FI	80	32	150	plain bore	110	100 x 85	80 x 60	9	40
LK-PATH 80KF	BK-PATH 80KF	LK-PATH 80KF-FI	80	32	150	ball bearing (C)	110	100 x 85	80 x 60	9	40
LK-PATH 100KF-1	BK-PATH 100KF-1	LK-PATH 100KF-1-FI	100	32	200	ball bearing (C)	130	100 x 85	80 x 60	9	45
LK-PATH 100KF-3	BK-PATH 100KF-3	LK-PATH 100KF-3-FI	100	32	200	ball bearing (C)	130	140 x 110	105 x 75–80	11	45
LK-PATH 125KF-1	BK-PATH 125KF-1	LK-PATH 125KF-1-FI	125	32	250	ball bearing (C)	155	100 x 85	80 x 60	9	48
LK-PATH 125KF-3	BK-PATH 125KF-3	LK-PATH 125KF-3-FI	125	32	250	ball bearing (C)	155	140 x 110	105 x 75–80	11	48
LK-PATH 160G	BH-PATH 160G	LK-PATH 160G-FI	160	40	400	plain bore	202	140 x 110	105 x 75–80	11	60
LK-PATH 160R	BH-PATH 160R	LK-PATH 160R-FI	160	40	400	roller bearing	202	140 x 110	105 x 75–80	11	60
LK-PATH 160KA	BH-PATH 160KA	LK-PATH 160KA-FI	160	40	400	ball bearing (C)	202	140 x 110	105 x 75–80	11	60
LK-PATH 200G	BH-PATH 200G	LK-PATH 200G-FI	200	40	500	plain bore	245	140 x 110	105 x 75–80	11	62
LK-PATH 200R	BH-PATH 200R	LK-PATH 200R-FI	200	40	500	roller bearing	245	140 x 110	105 x 75–80	11	62
LK-PATH 200KA	BH-PATH 200KA	LK-PATH 200KA-FI	200	40	500	ball bearing (C)	245	140 x 110	105 x 75–80	11	62

Versions / options



	ball bearing version KF	electrically conductive version, non-marking grey	with "stop-top" brake	with directional lock (separate) 1x 360°	small thread guard with additional ball bearing seal	large thread guard with additional ball bearing seals	with steel foot guard
Technical description page	50	112	115	85	85	116	
Product code suffix	-ELS	-ST	see **	-KAD	-KFD	-FS	
Available for	all ball bearing versions*	all	for wheel Ø and plate dimensions, see**	upon request	upon request	upon request	

* Wheel load capacity of electrically conductive version reduced by 35%

** RI-05.01 for wheel Ø 80–125 mm with plate 100x85 mm, RI-03.03 for wheel Ø 100–125 mm with plate 140x110 mm, RI-05.03 for wheel Ø 160–200 mm (Only for swivel castors without brake or swivel castor with "stop-top" brake upon request)

POTH series

Wheels with thermoplastic polyurethane tread, with heavy-duty nylon wheel centre



200–1,000 kg

Tread and tyre hardness

94 Shore A

Smooth operation / floor preservation

good

Rolling resistance

very good

Wear resistance

very good

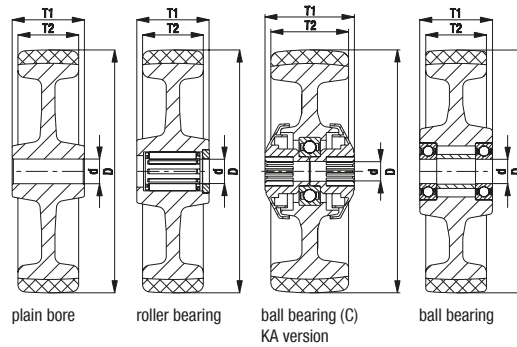

Tread:

- high-quality thermoplastic polyurethane (TPU), hardness 94 Shore A
- low rolling and swivel resistance
- high abrasion resistance
- colour dark grey, non-marking, non-staining
- chemically-bonded inseparable connection with the wheel centre

Wheel centre:

- high-quality nylon 6, impact resistant
- colour natural white

Other features:

- KA version: with synthetic thread guard, small
- very high chemical resistance to many aggressive substances
- operating temperature: -20 °C to +70 °C, temporarily up to +90 °C, reduced load capacity over +35 °C

Additional details:

- wheel series: page 65
- tread: page 55
- bearing types: page 84–85
- chemical resistance: page 51

Wheels	Wheel Ø (D) [mm]	Wheel width (T2) [mm]	Load capacity [kg]	Bearing type	Axle bore Ø (d) [mm]	Hub length (T1) [mm]
POTH 75/15G	75	37	200	plain bore	15	45
POTH 75/15R	75	37	200	roller bearing	15	45
POTH 100/12G	100	35	300	plain bore	12	45
POTH 100/15G	100	35	300	plain bore	15	45
POTH 100/12R	100	35	300	roller bearing	12	45
POTH 100/15R	100	35	300	roller bearing	15	45
POTH 100/8KA	100	35	300	ball bearing (C)	8	46
POTH 100/10KA	100	35	300	ball bearing (C)	10	46
POTH 100/15K	100	35	300	ball bearing	15	45
POTH 125/12G	125	40	350	plain bore	12	45
POTH 125/15G	125	40	350	plain bore	15	45
POTH 125/12R	125	40	350	roller bearing	12	45
POTH 125/15R	125	40	350	roller bearing	15	45
POTH 125/8KA	125	40	350	ball bearing (C)	8	46
POTH 125/10KA	125	40	350	ball bearing (C)	10	46
POTH 125/15K	125	40	350	ball bearing	15	45
POTH 150/20G	150	45	500	plain bore	20	60
POTH 150/20R	150	45	500	roller bearing	20	60
POTH 150/20K	150	45	500	ball bearing	20	60
POTH 160/20G	160	45	550	plain bore	20	60
POTH 160/20R	160	45	550	roller bearing	20	60
POTH 160/20K	160	45	550	ball bearing	20	60
POTH 200/20G	200	50	800	plain bore	20	60
POTH 200/20R	200	50	600	roller bearing	20	60
POTH 200/20K	200	50	800	ball bearing	20	60
POTH 200/25K	200	50	800	ball bearing	25	60
POTH 250/25G	250	50	1,000	plain bore	25	60
POTH 250/25K	250	50	1,000	ball bearing	25	60

5

Versions / options



	with stainless steel roller bearing in the wheel hub	with stainless steel ball bearing in the wheel hub	small thread guard with additional ball bearing seal	with corrosion-resistant wheel bearing and soft tread
Technical description page	84	84 / 85	85	270–273
Product code suffix	-XR	-XK / -XKA	-KAD	POTHS series
Available for	all	upon request	all ball bearings (C)	see series POTHS

L-POTH, B-POTH, BH-POTH series

Pressed steel castors, medium-duty version, with top plate, wheel with thermoplastic polyurethane tread

250–500 kg



Bracket: L/B/BH series

- pressed steel, zinc-plated, blue-passivated, Cr6-free

Swivel bracket:

- double ball bearing in the swivel head
- strong central kingpin (from wheel Ø 150 mm)
- swivel head seal
- minimum swivel head play and smooth rolling characteristic and increased service life due to the special dynamic Blickle riveting process

Wheel: POTH series

- tread: high-quality thermoplastic polyurethane (TPU), hardness 94 Shore A, colour dark grey, non-marking, non-staining
- wheel centre: high-quality nylon 6, impact resistant, colour natural white

Additional details:

- bracket series: page 91
- brakes: page 112–113
- wheel series: page 263
- bearing types: page 84–85

5

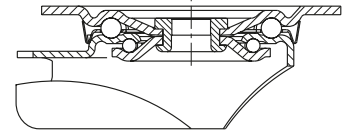

Swivel castors	Fixed castors	Swivel castors with "stop-fix" brake	Wheel Ø [mm]	Wheel width [mm]	Load capacity [kg]	Bearing type	Total height [mm]	Plate size [mm]	Bolt hole spacing [mm]	Bolt hole Ø [mm]	Offset swivel castor [mm]
L-POTH 100G	B-POTH 100G	L-POTH 100G-FI	100	35	250	plain bore	125	100 x 85	80 x 60	9	36
L-POTH 100R	B-POTH 100R	L-POTH 100R-FI	100	35	250	roller bearing	125	100 x 85	80 x 60	9	36
L-POTH 100KA	B-POTH 100KA	L-POTH 100KA-FI	100	35	250	ball bearing (C)	125	100 x 85	80 x 60	9	36
L-POTH 125G	B-POTH 125G	L-POTH 125G-FI	125	40	250	plain bore	150	100 x 85	80 x 60	9	38
L-POTH 125R	B-POTH 125R	L-POTH 125R-FI	125	40	250	roller bearing	150	100 x 85	80 x 60	9	38
L-POTH 125KA	B-POTH 125KA	L-POTH 125KA-FI	125	40	250	ball bearing (C)	150	100 x 85	80 x 60	9	38
L-POTH 150G	B-POTH 150G	L-POTH 150G-FI	150	45	400	plain bore	190	140 x 110	105 x 75–80	11	60
L-POTH 150R	B-POTH 150R	L-POTH 150R-FI	150	45	400	roller bearing	190	140 x 110	105 x 75–80	11	60
L-POTH 150K	B-POTH 150K	L-POTH 150K-FI	150	45	400	ball bearing	190	140 x 110	105 x 75–80	11	60
L-POTH 160G	B-POTH 160G	L-POTH 160G-FI	160	45	400	plain bore	195	140 x 110	105 x 75–80	11	60
L-POTH 160R	B-POTH 160R	L-POTH 160R-FI	160	45	400	roller bearing	195	140 x 110	105 x 75–80	11	60
L-POTH 160K	B-POTH 160K	L-POTH 160K-FI	160	45	400	ball bearing	195	140 x 110	105 x 75–80	11	60
L-POTH 200G	B-POTH 200G	L-POTH 200G-FI	200	50	400	plain bore	235	140 x 110	105 x 75–80	11	65
L-POTH 200R	B-POTH 200R	L-POTH 200R-FI	200	50	400	roller bearing	235	140 x 110	105 x 75–80	11	65
L-POTH 200K	B-POTH 200K	L-POTH 200K-FI	200	50	400	ball bearing	235	140 x 110	105 x 75–80	11	65
L-POTH 250G-3	BH-POTH 250G	*	250	50	500	plain bore	295	140 x 110	105 x 75–80	11	77
L-POTH 250K-3	BH-POTH 250K	*	250	50	500	ball bearing	295	140 x 110	105 x 75–80	11	77

* "stop-top" brake version, see versions / options

For stainless steel versions, see page 413

Versions / options



	with thread guard, pressed steel, zinc-plated	with "stop-top" brake	with "central-stop" central brake system	directional lock (separate) 1 x 360°	with steel foot guard	small thread guard with additional ball bearing seal	with corrosion-resistant wheel bearing and soft tread
Technical description page	116	112	113	115	116	85	270–273
Product code suffix	-FA	-ST	-CS11	RI-03.01 / RI-05.03	-FS	-KAD	POTHs series
Available for	wheel Ø 100–200 mm	all	wheel Ø 160–200 mm	RI-03.01: Ø 100–125 RI-05.03: Ø 150–200 **	all	upon request	see series L-POTHs

** Only for swivel castors without brake or swivel castor with "stop-top" and "central-stop" brake upon request

LK-POTH, BK-POTH, BH-POTH series

Pressed steel castors, heavy-duty design, with top plate, wheel with thermoplastic polyurethane tread



200–600 kg

Bracket: LK/BK/BH series

- strong pressed steel, zinc-plated, blue-passivated, Cr6-free

Swivel bracket:

- double ball bearing in the swivel head
- strong central kingpin (from wheel Ø 125x50 mm)
- swivel head seal
- minimum swivel head play and smooth rolling characteristic and increased service life due to the special dynamic Blickle riveting process

Wheel: POTH series

- tread: high-quality thermoplastic polyurethane (TPU), hardness 94 Shore A, colour dark grey, non-marking, non-staining
- wheel centre: high-quality nylon 6, impact resistant, colour natural white

Additional details:

- bracket series: page 92
- brakes: page 112–113
- wheel series: page 263
- bearing types: page 84–85

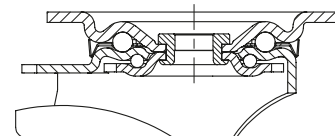

5

Swivel castors	Fixed castors	Swivel castors with "stop-fix" brake	Wheel Ø [mm]	Wheel width [mm]	Load capacity [kg]	Bearing type	Total height [mm]	Plate size [mm]	Bolt hole spacing [mm]	Bolt hole Ø [mm]	Offset swivel castor [mm]
LK-POTH 75G	BK-POTH 75G	LK-POTH 75G-FI	75	37	200	plain bore	108	100 x 85	80 x 60	9	40
LK-POTH 75R	BK-POTH 75R	LK-POTH 75R-FI	75	37	200	roller bearing	108	100 x 85	80 x 60	9	40
LK-POTH 100G-1	BK-POTH 100G-1	LK-POTH 100G-1-FI	100	35	300	plain bore	130	100 x 85	80 x 60	9	45
LK-POTH 100R-1	BK-POTH 100R-1	LK-POTH 100R-1-FI	100	35	300	roller bearing	130	100 x 85	80 x 60	9	45
LK-POTH 100KA-1	BK-POTH 100KA-1	LK-POTH 100KA-1-FI	100	35	300	ball bearing (C)	130	100 x 85	80 x 60	9	45
LK-POTH 100G-3	BK-POTH 100G-3	LK-POTH 100G-3-FI	100	35	300	plain bore	130	140 x 110	105 x 75–80	11	45
LK-POTH 100R-3	BK-POTH 100R-3	LK-POTH 100R-3-FI	100	35	300	roller bearing	130	140 x 110	105 x 75–80	11	45
LK-POTH 100KA-3	BK-POTH 100KA-3	LK-POTH 100KA-3-FI	100	35	300	ball bearing (C)	130	140 x 110	105 x 75–80	11	45
LK-POTH 125G-1	BK-POTH 125G-1	LK-POTH 125G-1-FI	125	40	350	plain bore	155	100 x 85	80 x 60	9	48
LK-POTH 125R-1	BK-POTH 125R-1	LK-POTH 125R-1-FI	125	40	350	roller bearing	155	100 x 85	80 x 60	9	48
LK-POTH 125KA-1	BK-POTH 125KA-1	LK-POTH 125KA-1-FI	125	40	350	ball bearing (C)	155	100 x 85	80 x 60	9	48
LK-POTH 125G-3	BK-POTH 125G-3	LK-POTH 125G-3-FI	125	40	350	plain bore	155	140 x 110	105 x 75–80	11	48
LK-POTH 125R-3	BK-POTH 125R-3	LK-POTH 125R-3-FI	125	40	350	roller bearing	155	140 x 110	105 x 75–80	11	48
LK-POTH 125KA-3	BK-POTH 125KA-3	LK-POTH 125KA-3-FI	125	40	350	ball bearing (C)	155	140 x 110	105 x 75–80	11	48
LK-POTH 150G	BH-POTH 150G	LK-POTH 150G-FI	150	45	500	plain bore	197	140 x 110	105 x 75–80	11	60
LK-POTH 150R	BH-POTH 150R	LK-POTH 150R-FI	150	45	500	roller bearing	197	140 x 110	105 x 75–80	11	60
LK-POTH 150K	BH-POTH 150K	LK-POTH 150K-FI	150	45	500	ball bearing	197	140 x 110	105 x 75–80	11	60
LK-POTH 160K	BH-POTH 160K	LK-POTH 160K-FI	160	45	550	ball bearing	202	140 x 110	105 x 75–80	11	60
LK-POTH 200G	BH-POTH 200G	LK-POTH 200G-FI	200	50	600	plain bore	245	140 x 110	105 x 75–80	11	62
LK-POTH 200R	BH-POTH 200R	LK-POTH 200R-FI	200	50	600	roller bearing	245	140 x 110	105 x 75–80	11	62
LK-POTH 200K	BH-POTH 200K	LK-POTH 200K-FI	200	50	600	ball bearing	245	140 x 110	105 x 75–80	11	62

For stainless steel versions, see page 414

Versions / options



	with thread guard, pressed steel, zinc-plated	with "stop-top" brake	with "ideal-stop" brake total height +17 mm	with directional lock (separate) 1x 360°	with steel foot guard	small thread guard with additional ball bearing seal	with corrosion-resistant wheel bearing and soft tread
Technical description page	116	112	112	115	116	85	270–273
Product code suffix	-FA	-ST	-IS	see **	-FS	-KAD	POTHs series
Available for	wheel Ø 100–200 mm	all	wheel Ø 160–200 mm*	for wheel Ø and plate dimensions, see**	upon request	upon request	see series LK-POTHs

* Synthetic adapter plate to balance out total height for swivel and fixed castors without "ideal-stop" brake: **product code AP3-17**

** **RI-05.01** for wheel Ø 75–125 mm with plate 100x85 mm, **RI-03.03** for wheel Ø 100–125 mm with plate 140x110 mm, **RI-05.03** for wheel Ø 150–200 mm (Only for swivel castors without brake or swivel castor with "stop-top" brake upon request)

LKR-POTH series

Pressed steel castors, heavy-duty design, with bolt hole, wheel with thermoplastic polyurethane tread



200–350 kg

Bracket: LKR series

- strong pressed steel, zinc-plated, blue-passivated, Cr6-free
- double ball bearing in the swivel head
- strong central kingpin
- minimum swivel head play and smooth rolling characteristic and increased service life due to the special dynamic Blickle riveting process

Wheel: POTH series

- tread: high-quality thermoplastic polyurethane (TPU), hardness 94 Shore A, colour dark grey, non-marking, non-staining
- wheel centre: high-quality nylon 6, impact resistant, colour natural white

Additional details:

- bracket series: page 92
- brakes: page 112–113
- wheel series: page 263
- bearing types: page 84–85

5

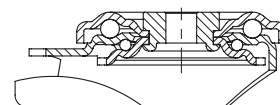

Swivel castors	Swivel castors with "stop-fix" brake	Wheel Ø [mm]	Wheel width [mm]	Load capacity [kg]	Bearing type	Total height [mm]	Plate Ø [mm]	Bolt hole Ø [mm]	Offset swivel castor [mm]
LKR-POTH 75G	LKR-POTH 75G-FI	75	37	200	plain bore	108	88	13	40
LKR-POTH 75R	LKR-POTH 75R-FI	75	37	200	roller bearing	108	88	13	40
LKR-POTH 100G	LKR-POTH 100G-FI	100	35	300	plain bore	130	88	13	45
LKR-POTH 100R	LKR-POTH 100R-FI	100	35	300	roller bearing	130	88	13	45
LKR-POTH 100KA	LKR-POTH 100KA-FI	100	35	300	ball bearing (C)	130	88	13	45
LKR-POTH 125G	LKR-POTH 125G-FI	125	40	350	plain bore	155	88	13	48
LKR-POTH 125R	LKR-POTH 125R-FI	125	40	350	roller bearing	155	88	13	48
LKR-POTH 125KA	LKR-POTH 125KA-FI	125	40	350	ball bearing (C)	155	88	13	48

Versions / options



	with thread guard, pressed steel, zinc-plated	small thread guard with additional ball bearing seal	truck lock
Technical description page	116	85	114
Product code suffix	-FA	-KAD	FF 100-1 / FF 125-1
Available for	wheel Ø 100–125 mm	upon request	wheel Ø 100+125 mm

LH-POTH, BH-POTH series, wheel Ø 75–125 mm

Pressed steel castors, heavy-duty design, with top plate, wheel with thermoplastic polyurethane tread



200–350 kg

Bracket: LH/BH series

- strong pressed steel, zinc-plated, blue-passivated, Cr6-free
- heavy fork and top plate

Swivel bracket:

- double ball bearing in the swivel head
- bolted and secured central kingpin, extremely strong
- particularly resistant to shocks and impact due to **four specially-shaped, hardened bearing seats**

Wheel: POTH series

- tread: high-quality thermoplastic polyurethane (TPU), hardness 94 Shore A, colour dark grey, non-marking, non-staining
- wheel centre: high-quality nylon 6, impact resistant, colour natural white

Additional details:

- bracket series: page 92
- brakes: page 112–113
- wheel series: page 263
- bearing types: page 84–85

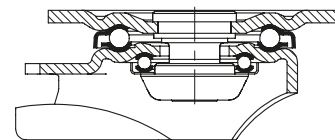

5

Swivel castors	Fixed castors	Swivel castors with "stop-fix" brake	Wheel Ø [mm]	Wheel width [mm]	Load capacity [kg]	Bearing type	Total height [mm]	Plate size [mm]	Bolt hole spacing [mm]	Bolt hole Ø [mm]	Offset swivel castor [mm]
LH-POTH 75G	BH-POTH 75G	LH-POTH 75G-FI	75	37	200	plain bore	118	100 x 85	80 x 60	9	45
LH-POTH 75R	BH-POTH 75R	LH-POTH 75R-FI	75	37	200	roller bearing	118	100 x 85	80 x 60	9	45
LH-POTH 100G-1	BH-POTH 100G-1	LH-POTH 100G-1-FI	100	35	300	plain bore	140	100 x 85	80 x 60	9	45
LH-POTH 100R-1	BH-POTH 100R-1	LH-POTH 100R-1-FI	100	35	300	roller bearing	140	100 x 85	80 x 60	9	45
LH-POTH 100K-1	BH-POTH 100K-1	LH-POTH 100K-1-FI	100	35	300	ball bearing	140	100 x 85	80 x 60	9	45
LH-POTH 100G-3	BH-POTH 100G-3	LH-POTH 100G-3-FI	100	35	300	plain bore	140	140 x 110	105 x 75–80	11	45
LH-POTH 100R-3	BH-POTH 100R-3	LH-POTH 100R-3-FI	100	35	300	roller bearing	140	140 x 110	105 x 75–80	11	45
LH-POTH 100K-3	BH-POTH 100K-3	LH-POTH 100K-3-FI	100	35	300	ball bearing	140	140 x 110	105 x 75–80	11	45
LH-POTH 125G-1	BH-POTH 125G-1	LH-POTH 125G-1-FI	125	40	350	plain bore	165	100 x 85	80 x 60	9	45
LH-POTH 125R-1	BH-POTH 125R-1	LH-POTH 125R-1-FI	125	40	350	roller bearing	165	100 x 85	80 x 60	9	45
LH-POTH 125K-1	BH-POTH 125K-1	LH-POTH 125K-1-FI	125	40	350	ball bearing	165	100 x 85	80 x 60	9	45
LH-POTH 125G-3	BH-POTH 125G-3	LH-POTH 125G-3-FI	125	40	350	plain bore	165	140 x 110	105 x 75–80	11	45
LH-POTH 125R-3	BH-POTH 125R-3	LH-POTH 125R-3-FI	125	40	350	roller bearing	165	140 x 110	105 x 75–80	11	45
LH-POTH 125K-3	BH-POTH 125K-3	LH-POTH 125K-3-FI	125	40	350	ball bearing	165	140 x 110	105 x 75–80	11	45

For other wheel Ø, see next page

Versions / options



	with thread guard, pressed steel, zinc-plated	with "stop-top" brake	directional lock (separate) 1 x 360°	directional lock (separate) 1 x 360°	with steel foot guard
Technical description page	116	112	115	115	116
Product code suffix	-FA	-ST	RI-04.01	RI-04.03	-FS
Available for	wheel Ø 100–125 mm	all	wheel Ø 75–125 mm with plate 100x85 mm*	wheel Ø 100–125 mm with plate 140x110 mm*	all from wheel Ø 100 mm

* Only for swivel castors without brake or swivel castor with "stop-top" brake upon request

LH-POTH, BH-POTH series, wheel Ø 150–250 mm

Pressed steel castors, heavy-duty design, with top plate, wheel with thermoplastic polyurethane tread



500–900 kg

Bracket: LH/BH series

- strong pressed steel, zinc-plated, blue-passivated, Cr6-free
- heavy fork and top plate

Swivel bracket:

- double ball bearing in the swivel head
- bolted and secured central kingpin, extremely strong
- particularly resistant to shocks and impact due to **four specially-shaped, hardened bearing seats**

Wheel: POTH series

- tread: high-quality thermoplastic polyurethane (TPU), hardness 94 Shore A, colour dark grey, non-marking, non-staining
- wheel centre: high-quality nylon 6, impact resistant, colour natural white

Additional details:

- bracket series: page 92
- brakes: page 112–113
- wheel series: page 263
- bearing types: page 84–85

5

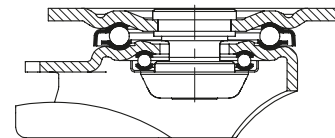

Swivel castors	Fixed castors	Swivel castors with "stop-fix" brake	Wheel Ø [mm]	Wheel width [mm]	Load capacity [kg]	Bearing type	Total height [mm]	Plate size [mm]	Bolt hole spacing [mm]	Bolt hole Ø [mm]	Offset swivel castor [mm]
LH-POTH 150G	BH-POTH 150G	LH-POTH 150G-FI	150	45	500	plain bore	197	140 x 110	105 x 75–80	11	65
LH-POTH 150R	BH-POTH 150R	LH-POTH 150R-FI	150	45	500	roller bearing	197	140 x 110	105 x 75–80	11	65
LH-POTH 150K	BH-POTH 150K	LH-POTH 150K-FI	150	45	500	ball bearing	197	140 x 110	105 x 75–80	11	65
LH-POTH 160G	BH-POTH 160G	LH-POTH 160G-FI	160	45	550	plain bore	202	140 x 110	105 x 75–80	11	65
LH-POTH 160R	BH-POTH 160R	LH-POTH 160R-FI	160	45	550	roller bearing	202	140 x 110	105 x 75–80	11	65
LH-POTH 160K	BH-POTH 160K	LH-POTH 160K-FI	160	45	550	ball bearing	202	140 x 110	105 x 75–80	11	65
LH-POTH 200G	BH-POTH 200G	LH-POTH 200G-FI	200	50	800	plain bore	245	140 x 110	105 x 75–80	11	70
LH-POTH 200R	BH-POTH 200R	LH-POTH 200R-FI	200	50	600	roller bearing	245	140 x 110	105 x 75–80	11	70
LH-POTH 200K	BH-POTH 200K	LH-POTH 200K-FI	200	50	800	ball bearing	245	140 x 110	105 x 75–80	11	70
LH-POTH 250G	BH-POTH 250G	*	250	50	900	plain bore	295	140 x 110	105 x 75–80	11	82
LH-POTH 250K	BH-POTH 250K	*	250	50	900	ball bearing	295	140 x 110	105 x 75–80	11	82

* "stop-top" brake version, see versions / options

Versions / options



	with thread guard, pressed steel, zinc-plated	with "stop-top" brake	directional lock (separate) 1 x 360°	with steel foot guard
Technical description page	116	112	115	116
Product code suffix	-FA	-ST	RI-05.03	-FS
Available for	wheel Ø 150–200 mm	all	wheel Ø 150–200 mm**	all

** Only for swivel castors without brake or swivel castor with "stop-top" brake upon request

LUH-POTH, BH-POTH series

Pressed steel castors, heavy-duty design, enclosed, with top plate, wheel with thermoplastic polyurethane tread



350–800 kg

Bracket: LUH/BH series

- strong pressed steel, zinc-plated, blue-passivated, Cr6-free

Swivel bracket:

- four-point ball bearing for extremely heavy loads
- enclosed and sealed swivel head
- particularly resistant to shocks and impact due to **specialty-shaped, hardened bearing seats**

Wheel: POTH series

- tread: high-quality thermoplastic polyurethane (TPU), hardness 94 Shore A, colour dark grey, non-marking, non-staining
- wheel centre: high-quality nylon 6, impact resistant, colour natural white

Additional details:

- bracket series: page 93
- brakes: page 112–113
- wheel series: page 263
- bearing types: page 84–85

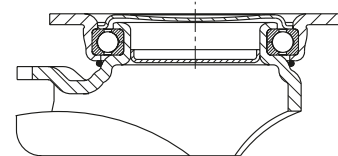

5

Swivel castors	Fixed castors	Swivel castors with "stop-fix" brake	Wheel Ø [mm]	Wheel width [mm]	Load capacity [kg]	Bearing type	Total height [mm]	Plate size [mm]	Bolt hole spacing [mm]	Bolt hole Ø [mm]	Offset swivel castor [mm]
LUH-POTH 125K	BH-POTH 125K-3	LUH-POTH 125K-FI	125	40	350	ball bearing	170	140 x 110	105 x 75–80	11	55
LUH-POTH 150G	BH-POTH 150G	LUH-POTH 150G-FI	150	45	500	plain bore	197	140 x 110	105 x 75–80	11	61
LUH-POTH 150R	BH-POTH 150R	LUH-POTH 150R-FI	150	45	500	roller bearing	197	140 x 110	105 x 75–80	11	61
LUH-POTH 150K	BH-POTH 150K	LUH-POTH 150K-FI	150	45	500	ball bearing	197	140 x 110	105 x 75–80	11	61
LUH-POTH 160G	BH-POTH 160G	LUH-POTH 160G-FI	160	45	550	plain bore	202	140 x 110	105 x 75–80	11	61
LUH-POTH 160R	BH-POTH 160R	LUH-POTH 160R-FI	160	45	550	roller bearing	202	140 x 110	105 x 75–80	11	61
LUH-POTH 160K	BH-POTH 160K	LUH-POTH 160K-FI	160	45	550	ball bearing	202	140 x 110	105 x 75–80	11	61
LUH-POTH 200G	BH-POTH 200G	LUH-POTH 200G-FI	200	50	800	plain bore	245	140 x 110	105 x 75–80	11	63
LUH-POTH 200R	BH-POTH 200R	LUH-POTH 200R-FI	200	50	600	roller bearing	245	140 x 110	105 x 75–80	11	63
LUH-POTH 200K	BH-POTH 200K	LUH-POTH 200K-FI	200	50	800	ball bearing	245	140 x 110	105 x 75–80	11	63

Versions / options



	with thread guard, pressed steel, zinc-plated	directional lock (separate) 1 x 360°	with steel foot guard	with corrosion-resistant wheel bearing and soft tread
Technical description page	116	115	116	270–273
Product code suffix	-FA	RI-05.03	-FS	POTHS series
Available for	all	all*	upon request	see series LUH-POTHS

* Only for swivel castors without brake

POTHS series

Wheels with soft thermoplastic polyurethane tread, with heavy-duty nylon wheel centre



200–550 kg

Tread and tyre hardness
 80 Shore A

Smooth operation / floor preservation
 very good

Rolling resistance
 very good

Wear resistance
 good

Tread:

- high-quality thermoplastic polyurethane (TPU), hardness 80 Shore A
- very good operational comfort
- low rolling and swivel resistance
- very good floor preservation, low-noise operation
- colour blue, non-marking, non-staining
- chemically-bonded inseparable connection with the wheel centre

Wheel centre:

- high-quality nylon 6, impact resistant
- colour natural white

Other features:

- KA version: with synthetic thread guard, small
- very high chemical resistance to many aggressive substances
- operating temperature: -20 °C to +70 °C, temporarily up to +90 °C, reduced load capacity over +35 °C

Additional details:

- wheel series: page 65
- tread: page 55
- bearing types: page 84–85
- chemical resistance: page 51

Wheels	Wheel Ø	Wheel width	Load capacity	Bearing type	Axle bore Ø	Hub length
	(D) [mm]	(T2) [mm]	[kg]		(d) [mm]	(T1) [mm]
POTHS 100/12G	100	35	200	plain bore	12	45
POTHS 100/15G	100	35	200	plain bore	15	45
POTHS 100/12R	100	35	200	roller bearing	12	45
POTHS 100/15R	100	35	200	roller bearing	15	45
POTHS 100/8KA	100	35	200	ball bearing (C)	8	46
POTHS 100/10KA	100	35	200	ball bearing (C)	10	46
POTHS 125/12G	125	40	275	plain bore	12	45
POTHS 125/15G	125	40	275	plain bore	15	45
POTHS 125/12R	125	40	275	roller bearing	12	45
POTHS 125/15R	125	40	275	roller bearing	15	45
POTHS 125/8KA	125	40	275	ball bearing (C)	8	46
POTHS 125/10KA	125	40	275	ball bearing (C)	10	46
POTHS 125/15K	125	40	275	ball bearing	15	45
POTHS 160/20G	160	45	400	plain bore	20	60
POTHS 160/20R	160	45	400	roller bearing	20	60
POTHS 160/20K	160	45	400	ball bearing	20	60
POTHS 200/20G	200	50	550	plain bore	20	60
POTHS 200/20R	200	50	550	roller bearing	20	60
POTHS 200/20K	200	50	550	ball bearing	20	60

Versions / options

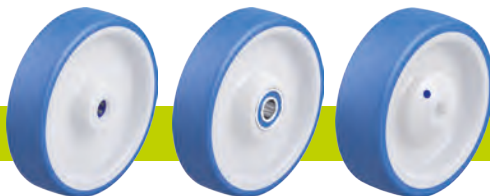

	with stainless steel roller bearing in the wheel hub	with stainless steel ball bearing in the wheel hub	with stainless steel ball bearing and small thread guard
Technical description page	84	84	85
Product code suffix	-XR	-XK	-XKA
Available for	all	wheel Ø 160–200 mm	wheel Ø 100–125 ball bearing (C)

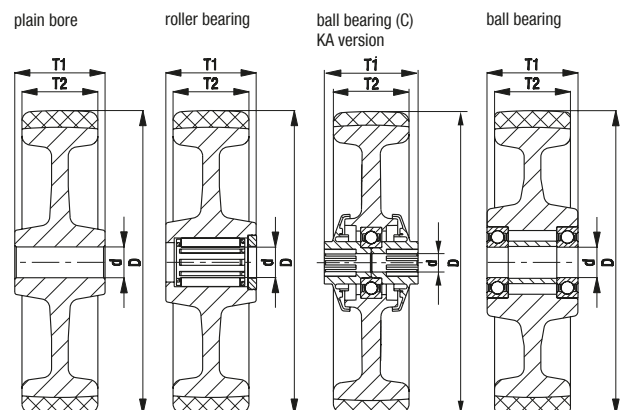

L-POTHS, B-POTHS series

Pressed steel castors, medium-duty design, with top plate, wheel with soft thermoplastic polyurethane tread

200–400 kg

Bracket: L/B series

- pressed steel, zinc-plated, blue-passivated, Cr6-free

Swivel bracket:

- double ball bearing in the swivel head
- strong central kingpin (from wheel Ø 150 mm)
- swivel head seal
- minimum swivel head play and smooth rolling characteristic and increased service life due to the special dynamic Blickle riveting process

Wheel: POTHS series

- tread: high-quality thermoplastic polyurethane (TPU), hardness 80 Shore A, colour blue, non-marking, non-staining
- wheel centre: high-quality nylon 6, impact resistant, colour natural white

Additional details:

- bracket series: page 91
- brakes: page 112–113
- wheel series: page 270
- bearing types: page 84–85

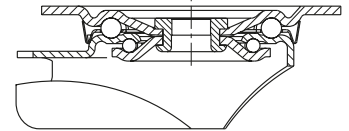

5

Swivel castors	Fixed castors	Swivel castors with "stop-fix" brake	Wheel Ø [mm]	Wheel width [mm]	Load capacity [kg]	Bearing type	Total height [mm]	Plate size [mm]	Bolt hole spacing [mm]	Bolt hole Ø [mm]	Offset swivel castor [mm]
L-POTHS 100G	B-POTHS 100G	L-POTHS 100G-FI	100	35	200	plain bore	125	100 x 85	80 x 60	9	36
L-POTHS 100R	B-POTHS 100R	L-POTHS 100R-FI	100	35	200	roller bearing	125	100 x 85	80 x 60	9	36
L-POTHS 100KA	B-POTHS 100KA	L-POTHS 100KA-FI	100	35	200	ball bearing (C)	125	100 x 85	80 x 60	9	36
L-POTHS 125G	B-POTHS 125G	L-POTHS 125G-FI	125	40	250	plain bore	150	100 x 85	80 x 60	9	38
L-POTHS 125R	B-POTHS 125R	L-POTHS 125R-FI	125	40	250	roller bearing	150	100 x 85	80 x 60	9	38
L-POTHS 125KA	B-POTHS 125KA	L-POTHS 125KA-FI	125	40	250	ball bearing (C)	150	100 x 85	80 x 60	9	38
L-POTHS 160G	B-POTHS 160G	L-POTHS 160G-FI	160	45	400	plain bore	195	140 x 110	105 x 75–80	11	60
L-POTHS 160R	B-POTHS 160R	L-POTHS 160R-FI	160	45	400	roller bearing	195	140 x 110	105 x 75–80	11	60
L-POTHS 160K	B-POTHS 160K	L-POTHS 160K-FI	160	45	400	ball bearing	195	140 x 110	105 x 75–80	11	60
L-POTHS 200G	B-POTHS 200G	L-POTHS 200G-FI	200	50	400	plain bore	235	140 x 110	105 x 75–80	11	65
L-POTHS 200R	B-POTHS 200R	L-POTHS 200R-FI	200	50	400	roller bearing	235	140 x 110	105 x 75–80	11	65
L-POTHS 200K	B-POTHS 200K	L-POTHS 200K-FI	200	50	400	ball bearing	235	140 x 110	105 x 75–80	11	65

For stainless steel versions, see page 412

Versions / options



	with thread guard, pressed steel, zinc-plated	with "stop-top" brake	with "central-stop" central brake system	directional lock (separate) 1 x 360°	with stainless steel roller bearing in the wheel hub	with stainless steel ball bearing in the wheel hub	with steel foot guard
Technical description page	116	112	113	115	84	84 / 85	116
Product code suffix	-FA	-ST	-CS11	RI-03.01 / RI-05.03	-XR	-XK / -XKA	-FS
Available for	all	all	wheel Ø 160–200 mm	RI-03.01: Ø 100–125 RI-05.03: Ø 160–200*	all	all	all

* Only for swivel castors without brake or swivel castor with "stop-top" and "central-stop" brake upon request

LK-POTHS, BK-POTHS, BH-POTHS series

Pressed steel castors, heavy-duty design, with top plate, wheel with soft thermoplastic polyurethane tread

200–550 kg



Bracket: LK/BK/BH series

- strong pressed steel, zinc-plated, blue-passivated, Cr6-free

Swivel bracket:

- double ball bearing in the swivel head
- strong central kingpin (from wheel Ø 125x50 mm)
- swivel head seal
- minimum swivel head play and smooth rolling characteristic and increased service life due to the special dynamic Blickle riveting process

Wheel: POTHS series

- tread: high-quality thermoplastic polyurethane (TPU), hardness 80 Shore A, colour blue, non-marking, non-staining
- wheel centre: high-quality nylon 6, impact resistant, colour natural white

Additional details:

- bracket series: page 92
- brakes: page 112–113
- wheel series: page 270
- bearing types: page 84–85

5

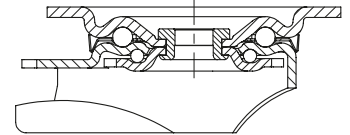

Swivel castors	Fixed castors	Swivel castors with "stop-fix" brake	Wheel Ø [mm]	Wheel width [mm]	Load capacity [kg]	Bearing type	Total height [mm]	Plate size [mm]	Bolt hole spacing [mm]	Bolt hole Ø [mm]	Offset swivel castor [mm]
LK-POTHS 100G-1	BK-POTHS 100G-1	LK-POTHS 100G-1-FI	100	35	200	plain bore	130	100 x 85	80 x 60	9	45
LK-POTHS 100R-1	BK-POTHS 100R-1	LK-POTHS 100R-1-FI	100	35	200	roller bearing	130	100 x 85	80 x 60	9	45
LK-POTHS 100KA-1	BK-POTHS 100KA-1	LK-POTHS 100KA-1-FI	100	35	200	ball bearing (C)	130	100 x 85	80 x 60	9	45
LK-POTHS 100G-3	BK-POTHS 100G-3	LK-POTHS 100G-3-FI	100	35	200	plain bore	130	140 x 110	105 x 75–80	11	45
LK-POTHS 100R-3	BK-POTHS 100R-3	LK-POTHS 100R-3-FI	100	35	200	roller bearing	130	140 x 110	105 x 75–80	11	45
LK-POTHS 100KA-3	BK-POTHS 100KA-3	LK-POTHS 100KA-3-FI	100	35	200	ball bearing (C)	130	140 x 110	105 x 75–80	11	45
LK-POTHS 125G-1	BK-POTHS 125G-1	LK-POTHS 125G-1-FI	125	40	275	plain bore	155	100 x 85	80 x 60	9	48
LK-POTHS 125R-1	BK-POTHS 125R-1	LK-POTHS 125R-1-FI	125	40	275	roller bearing	155	100 x 85	80 x 60	9	48
LK-POTHS 125KA-1	BK-POTHS 125KA-1	LK-POTHS 125KA-1-FI	125	40	275	ball bearing (C)	155	100 x 85	80 x 60	9	48
LK-POTHS 125G-3	BK-POTHS 125G-3	LK-POTHS 125G-3-FI	125	40	275	plain bore	155	140 x 110	105 x 75–80	11	48
LK-POTHS 125R-3	BK-POTHS 125R-3	LK-POTHS 125R-3-FI	125	40	275	roller bearing	155	140 x 110	105 x 75–80	11	48
LK-POTHS 125KA-3	BK-POTHS 125KA-3	LK-POTHS 125KA-3-FI	125	40	275	ball bearing (C)	155	140 x 110	105 x 75–80	11	48
LK-POTHS 160G	BH-POTHS 160G	LK-POTHS 160G-FI	160	45	400	plain bore	202	140 x 110	105 x 75–80	11	60
LK-POTHS 160R	BH-POTHS 160R	LK-POTHS 160R-FI	160	45	400	roller bearing	202	140 x 110	105 x 75–80	11	60
LK-POTHS 160K	BH-POTHS 160K	LK-POTHS 160K-FI	160	45	400	ball bearing	202	140 x 110	105 x 75–80	11	60
LK-POTHS 200G	BH-POTHS 200G	LK-POTHS 200G-FI	200	50	550	plain bore	245	140 x 110	105 x 75–80	11	62
LK-POTHS 200R	BH-POTHS 200R	LK-POTHS 200R-FI	200	50	550	roller bearing	245	140 x 110	105 x 75–80	11	62
LK-POTHS 200K	BH-POTHS 200K	LK-POTHS 200K-FI	200	50	550	ball bearing	245	140 x 110	105 x 75–80	11	62

Versions / options



	with thread guard, pressed steel, zinc-plated	with "stop-top" brake	with "ideal-stop" brake total height +17 mm	with directional lock (separate) 1x 360°	with stainless steel roller bearing in the wheel hub	with stainless steel ball bearing in the wheel hub	with steel foot guard
Technical description page	116	112	112	115	84	84 / 85	116
Product code suffix	-FA	-ST	-IS	see **	-XR	-XK / -XKA	-FS
Available for	all	all	wheel Ø 160–200 mm*	for wheel Ø and plate dimensions, see**	all	all	upon request

* Synthetic adapter plate to balance out total height for swivel and fixed castors without "ideal-stop" brake: **product code AP3-17**

** **RI-05.01** for wheel Ø 100–125 mm with plate 100x85 mm, **RI-03.03** for wheel Ø 100–125 mm with plate 140x110 mm, **RI-05.03** for wheel Ø 160–200 mm (Only for swivel castors without brake or swivel castor with "stop-top" brake upon request)

LUH-POTHS, BH-POTHS series

Pressed steel castors, heavy-duty design, enclosed, with top plate, wheel with soft thermoplastic polyurethane tread



275–550 kg

Bracket: LUH/BH series

- strong pressed steel, zinc-plated, blue-passivated, Cr6-free

Swivel bracket:

- four-point ball bearing for extremely heavy loads
- enclosed and sealed swivel head
- particularly resistant to shocks and impact due to **specialty-shaped, hardened bearing seats**

Wheel: POTHS series

- tread: high-quality thermoplastic polyurethane (TPU), hardness 80 Shore A, colour blue, non-marking, non-staining
- wheel centre: high-quality nylon 6, impact resistant, colour natural white

Additional details:

- bracket series: page 93
- brakes: page 112–113
- wheel series: page 270
- bearing types: page 84–85

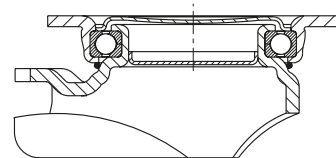

5

Swivel castors	Fixed castors	Swivel castors with "stop-fix" brake	Wheel Ø [mm]	Wheel width [mm]	Load capacity [kg]	Bearing type	Total height [mm]	Plate size [mm]	Bolt hole spacing [mm]	Bolt hole Ø [mm]	Offset swivel castor [mm]
LUH-POTHS 125K	BH-POTHS 125K-3	LUH-POTHS 125K-FI	125	40	275	ball bearing	170	140 x 110	105 x 75–80	11	55
LUH-POTHS 160G	BH-POTHS 160G	LUH-POTHS 160G-FI	160	45	400	plain bore	202	140 x 110	105 x 75–80	11	61
LUH-POTHS 160R	BH-POTHS 160R	LUH-POTHS 160R-FI	160	45	400	roller bearing	202	140 x 110	105 x 75–80	11	61
LUH-POTHS 160K	BH-POTHS 160K	LUH-POTHS 160K-FI	160	45	400	ball bearing	202	140 x 110	105 x 75–80	11	61
LUH-POTHS 200G	BH-POTHS 200G	LUH-POTHS 200G-FI	200	50	550	plain bore	245	140 x 110	105 x 75–80	11	63
LUH-POTHS 200R	BH-POTHS 200R	LUH-POTHS 200R-FI	200	50	550	roller bearing	245	140 x 110	105 x 75–80	11	63
LUH-POTHS 200K	BH-POTHS 200K	LUH-POTHS 200K-FI	200	50	550	ball bearing	245	140 x 110	105 x 75–80	11	63

Versions / options



	with thread guard, pressed steel, zinc-plated	directional lock (separate) 1 x 360°	with stainless steel roller bearing in the wheel hub	with stainless steel ball bearing in the wheel hub	with steel foot guard
Technical description page	116	115	84	84	116
Product code suffix	-FA	RI-05.03	-XR	-XK	-FS
Available for	all	all*	all	wheel Ø 160–200 mm	upon request

* Only for swivel castors without brake

ALTH series

Heavy-duty wheels
with **Blickle Extrathane®** polyurethane tread,
with aluminium wheel centre

200–1,250 kg

Tread and tyre hardness

92 Shore A

Smooth operation / floor preservation

good

Rolling resistance

very good

Wear resistance

excellent



Tread:

- high-quality polyurethane elastomer Blickle Extrathane®, hardness 92 Shore A
- low rolling resistance
- high abrasion resistance
- high cut and tear propagation resistance
- colour light brown, non-marking, non-staining
- excellent chemical connection with the wheel centre

Wheel centre:

- die-cast aluminium

Other features:

- high chemical resistance to many aggressive substances
- operating temperature: -20 °C to +70 °C, temporarily up to +90 °C, reduced load capacity over +40 °C

Additional details:

- wheel series: page 65
- tread: page 55
- bearing types: page 84–85
- chemical resistance: page 51

Wheels	Wheel Ø (D) [mm]	Wheel width (T2) [mm]	Load capacity at 4 km/h [kg]	Load capacity at 10 km/h [kg]	Bearing type	Axle bore Ø (d) [mm]	Hub length (T1) [mm]
ALTH 80/15K	80	30	200	–	ball bearing	15	35
ALTH 100/15K	100	40	350	–	ball bearing	15	45
ALTH 101/15K *	100	40	420	–	ball bearing	15	40
ALTH 101/15K-CO *	100	40	420	–	ball bearing	15	40
ALTH 125/15K	125	40	550	–	ball bearing	15	45
ALTH 125/15K-CO	125	40	550	–	ball bearing	15	45
ALTH 127/20K	125	54	750	370	ball bearing	20	60
ALTH 140/20K	140	54	800	400	ball bearing	20	60
ALTH 151/15K	150	40	400	200	ball bearing	15	60
ALTH 150/20K	150	50	650	320	ball bearing	20	60
ALTH 152/20K *	150	54	900	450	ball bearing	20	60
ALTH 160/20K	160	50	750	370	ball bearing	20	60
ALTH 160/20K-CO	160	50	750	300	ball bearing	20	60
ALTH 162/20K *	160	50	950	470	ball bearing	20	60
ALTH 180/20K	180	50	700	350	ball bearing	20	60
ALTH 200/20K	200	50	800	400	ball bearing	20	60
ALTH 200/20K-CO	200	50	800	320	ball bearing	20	60
ALTH 200/25K	200	50	800	400	ball bearing	25	60
ALTH 200/25K-CO	200	50	800	320	ball bearing	25	60
ALTH 202/20K *	200	50	1,000	500	ball bearing	20	60
ALTH 250/25K	250	60	1,000	500	ball bearing	25	70
ALTH 252/25K *	250	60	1,250	620	ball bearing	25	70

* With heavy-duty wheel centre, reinforced design

Versions / options



	version with extremely crowned tread	version with heavy duty wheel centre, reinforced design	antistatic version, non-marking grey	other shore hardnesses and special colours
Technical description page	55		50	
Product code suffix	-CO		-AS	
Available for			all with exception of wheel Ø 140 mm	upon request

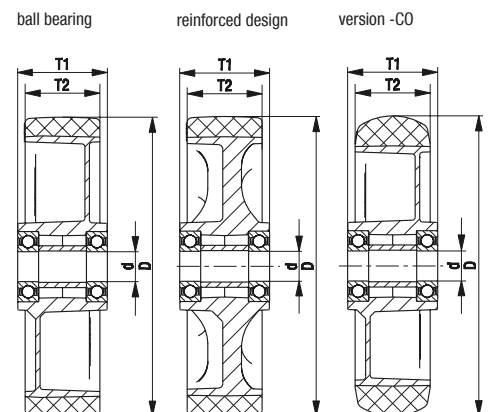

L-ALTH, B-ALTH, BH-ALTH series

Pressed steel castors, medium-duty version, with top plate, wheel with Blickle Extrathane® polyurethane tread



200–500 kg

Bracket: L/B/BH series

- pressed steel, zinc-plated, blue-passivated, Cr6-free

Swivel bracket:

- double ball bearing in the swivel head
- strong central kingpin (from wheel Ø 150 mm)
- swivel head seal
- minimum swivel head play and smooth rolling characteristic and increased service life due to the special dynamic Blickle riveting process

Wheel: ALTH series

- tread: high-quality polyurethane elastomer Blickle Extrathane®, hardness 92 Shore A, colour light brown, non-marking, non-staining
- wheel centre: die-cast aluminium, colour silver grey

Additional details:

- bracket series: page 91
- brakes: page 112–113
- wheel series: page 274
- bearing types: page 84–85

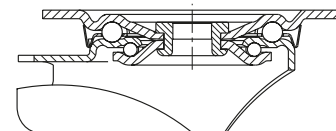

5

Swivel castors	Fixed castors	Swivel castors with "stop-fix" brake	Wheel Ø [mm]	Wheel width [mm]	Load capacity [kg]	Bearing type	Total height [mm]	Plate size [mm]	Bolt hole spacing [mm]	Bolt hole Ø [mm]	Offset swivel castor [mm]
L-ALTH 80K	B-ALTH 80K	L-ALTH 80K-FI	80	30	200	ball bearing	102	100 x 85	80 x 60	9	38
L-ALTH 100K	B-ALTH 100K	L-ALTH 100K-FI	100	40	250	ball bearing	125	100 x 85	80 x 60	9	36
L-ALTH 125K	B-ALTH 125K	L-ALTH 125K-FI	125	40	250	ball bearing	150	100 x 85	80 x 60	9	38
L-ALTH 125K-CO	B-ALTH 125K-CO	L-ALTH 125K-FI-CO	125	40	250	ball bearing	150	100 x 85	80 x 60	9	38
L-ALTH 151K	B-ALTH 151K	L-ALTH 151K-FI	150	40	400	ball bearing	190	140 x 110	105 x 75–80	11	60
L-ALTH 150K	B-ALTH 150K	L-ALTH 150K-FI	150	50	400	ball bearing	190	140 x 110	105 x 75–80	11	60
L-ALTH 160K	B-ALTH 160K	L-ALTH 160K-FI	160	50	400	ball bearing	195	140 x 110	105 x 75–80	11	60
L-ALTH 160K-CO	B-ALTH 160K-CO	L-ALTH 160K-FI-CO	160	50	400	ball bearing	195	140 x 110	105 x 75–80	11	60
L-ALTH 180K	B-ALTH 180K	L-ALTH 180K-FI	180	50	400	ball bearing	215	140 x 110	105 x 75–80	11	60
L-ALTH 200K	B-ALTH 200K	L-ALTH 200K-FI	200	50	400	ball bearing	235	140 x 110	105 x 75–80	11	65
L-ALTH 200K-CO	B-ALTH 200K-CO	L-ALTH 200K-FI-CO	200	50	400	ball bearing	235	140 x 110	105 x 75–80	11	65
L-ALTH 250K-3	BH-ALTH 250K	*	250	60	500	ball bearing	295	140 x 110	105 x 75–80	11	77

* "stop-top" brake version, see versions / options

Versions / options



	version with extremely crowned tread	antistatic version, non-marking grey	with "stop-top" brake	with "central-stop" central brake system	directional lock (separate) 1 x 360°	directional lock (separate) 1 x 360°	with steel foot guard
Technical description page	55	50	112	113	115	115	116
Product code suffix	-CO	-AS	-ST	-CS11	RI-03.01	RI-05.03	-FS
Available for		all	all	wheel Ø 160+200 mm	wheel Ø 100–125 mm**	wheel Ø 150–200 mm**	wheel Ø 100–250 mm

** Only for swivel castors without brake or swivel castor with "stop-top" and "central-stop" brake upon request

LK-ALTH, BK-ALTH, BH-ALTH series

Pressed steel castors, heavy-duty design, with top plate, wheel with Blickle Extrathane® polyurethane tread

200–600 kg

Bracket: LK/BK/BH series

- strong pressed steel, zinc-plated, blue-passivated, Cr6-free

Swivel bracket:

- double ball bearing in the swivel head
- strong central kingpin (from wheel Ø 125x50 mm)
- swivel head seal
- minimum swivel head play and smooth rolling characteristic and increased service life due to the special dynamic Blickle riveting process

Wheel: ALTH series

- tread: high-quality polyurethane elastomer Blickle Extrathane®, hardness 92 Shore A, colour light brown, non-marking, non-staining
- wheel centre: die-cast aluminium, colour silver grey

Additional details:

- bracket series: page 92
- brakes: page 112–113
- wheel series: page 274
- bearing types: page 84–85



5

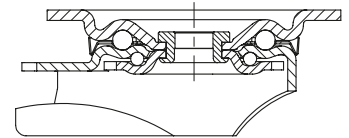

Swivel castors	Fixed castors	Swivel castors with "stop-fix" brake	Wheel Ø [mm]	Wheel width [mm]	Load capacity [kg]	Bearing type	Total height [mm]	Plate size [mm]	Bolt hole spacing [mm]	Bolt hole Ø [mm]	Offset swivel castor [mm]
LK-ALTH 80K	BK-ALTH 80K	LK-ALTH 80K-FI	80	30	200	ball bearing	110	100 x 85	80 x 60	9	40
LK-ALTH 100K-1	BK-ALTH 100K-1	LK-ALTH 100K-1-FI	100	40	350	ball bearing	130	100 x 85	80 x 60	9	45
LK-ALTH 100K-3	BK-ALTH 100K-3	LK-ALTH 100K-3-FI	100	40	350	ball bearing	130	140 x 110	105 x 75–80	11	45
LK-ALTH 125K-1	BK-ALTH 125K-1	LK-ALTH 125K-1-FI	125	40	350	ball bearing	155	100 x 85	80 x 60	9	48
LK-ALTH 125K-1-CO	BK-ALTH 125K-1-CO	LK-ALTH 125K-1-FI-CO	125	40	350	ball bearing	155	100 x 85	80 x 60	9	48
LK-ALTH 125K-3	BK-ALTH 125K-3	LK-ALTH 125K-3-FI	125	40	350	ball bearing	155	140 x 110	105 x 75–80	11	48
LK-ALTH 125K-3-CO	BK-ALTH 125K-3-CO	LK-ALTH 125K-3-FI-CO	125	40	350	ball bearing	155	140 x 110	105 x 75–80	11	48
LK-ALTH 127K	BH-ALTH 127K	LK-ALTH 127K-FI	125	54	600	ball bearing	170	140 x 110	105 x 75–80	11	55
LK-ALTH 150K	BH-ALTH 150K	LK-ALTH 150K-FI	150	50	600	ball bearing	197	140 x 110	105 x 75–80	11	60
LK-ALTH 160K	BH-ALTH 160K	LK-ALTH 160K-FI	160	50	600	ball bearing	202	140 x 110	105 x 75–80	11	60
LK-ALTH 160K-CO	BH-ALTH 160K-CO	LK-ALTH 160K-FI-CO	160	50	600	ball bearing	202	140 x 110	105 x 75–80	11	60
LK-ALTH 180K	BH-ALTH 180K	LK-ALTH 180K-FI	180	50	600	ball bearing	223	140 x 110	105 x 75–80	11	65
LK-ALTH 200K	BH-ALTH 200K	LK-ALTH 200K-FI	200	50	600	ball bearing	245	140 x 110	105 x 75–80	11	62
LK-ALTH 200K-CO	BH-ALTH 200K-CO	LK-ALTH 200K-FI-CO	200	50	600	ball bearing	245	140 x 110	105 x 75–80	11	62

Versions / options



	version with extremely crowned tread	antistatic version, non-marking grey	with "stop-top" brake	with "ideal-stop" brake total height +17 mm	with directional lock (separate) 1x 360°	with steel foot guard
Technical description page	55	50	112	112	115	116
Product code suffix	-CO	-AS	-ST	-IS	see **	-FS
Available for		all	all	wheel Ø 160+200 mm*	for wheel Ø and plate dimensions, see**	upon request

* Synthetic adapter plate to balance out total height for swivel and fixed castors without "ideal-stop" brake: **product code AP3-17**

** **RI-05.01** for wheel Ø 80–125 mm with plate 100x85 mm, **RI-03.03** for wheel Ø 100–125x40 mm with plate 140x110 mm, **RI-05.03** for wheel Ø 125x54–200 mm (Only for swivel castors without brake or swivel castor with "stop-top" brake upon request)

LKR-ALTH series

Pressed steel castors, heavy-duty design, with bolt hole, wheel with Blickle Extrathane® polyurethane tread



200–350 kg

Bracket: LKR series

- strong pressed steel, zinc-plated, blue-passivated, Cr6-free
- double ball bearing in the swivel head
- strong central kingpin
- minimum swivel head play and smooth rolling characteristic and increased service life due to the special dynamic Blickle riveting process

Wheel: ALTH series

- tread: high-quality polyurethane elastomer Blickle Extrathane®, hardness 92 Shore A, colour light brown, non-marking, non-staining
- wheel centre: die-cast aluminium, colour silver grey

Additional details:

- bracket series: page 92
- brakes: page 112–113
- wheel series: page 274
- bearing types: page 84–85

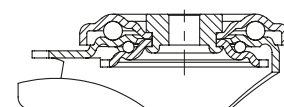

5

Swivel castors	Swivel castors with "stop-fix" brake	Wheel Ø [mm]	Wheel width [mm]	Load capacity [kg]	Bearing type	Total height [mm]	Plate Ø [mm]	Bolt hole Ø [mm]	Offset swivel castor [mm]
LKR-ALTH 80K	LKR-ALTH 80K-FI	80	30	200	ball bearing	110	88	13	40
LKR-ALTH 100K	LKR-ALTH 100K-FI	100	40	350	ball bearing	130	88	13	45
LKR-ALTH 125K	LKR-ALTH 125K-FI	125	40	350	ball bearing	155	88	13	48
LKR-ALTH 125K-CO	LKR-ALTH 125K-FI-CO	125	40	350	ball bearing	155	88	13	48

Versions / options



	version with extremely crowned tread	antistatic version, non-marking grey	truck lock
Technical description page	55	50	114
Product code suffix	-CO	-AS	FF 100-1 / FF 125-1
Available for		all	wheel Ø 100+125 mm

LH-ALTH, BH-ALTH series

Pressed steel castors, heavy-duty design, with top plate, wheel with Blickle Extrathane® polyurethane tread

200–900 kg



Bracket: LH/BH series

- strong pressed steel, zinc-plated, blue-passivated, Cr6-free
- heavy fork and top plate

Swivel bracket:

- double ball bearing in the swivel head
- bolted and secured central kingpin, extremely strong
- particularly resistant to shocks and impact due to **four specially-shaped, hardened bearing seats**

Wheel: ALTH series

- tread: high-quality polyurethane elastomer Blickle Extrathane®, hardness 92 Shore A, colour light brown, non-marking, non-staining
- wheel centre: die-cast aluminium, colour silver grey

Additional details:

- bracket series: page 92
- brakes: page 112–113
- wheel series: page 274
- bearing types: page 84–85



5

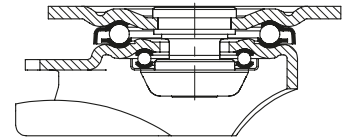

Swivel castors	Fixed castors	Swivel castors with "stop-fix" brake	Wheel Ø [mm]	Wheel width [mm]	Load capacity [kg]	Bearing type	Total height [mm]	Plate size [mm]	Bolt hole spacing [mm]	Bolt hole Ø [mm]	Offset swivel castor [mm]
LH-ALTH 80K	BH-ALTH 80K	LH-ALTH 80K-FI	80	30	200	ball bearing	120	100 x 85	80 x 60	9	45
LH-ALTH 100K-1	BH-ALTH 100K-1	LH-ALTH 100K-1-FI	100	40	350	ball bearing	140	100 x 85	80 x 60	9	45
LH-ALTH 101K-1 *	BH-ALTH 101K-1 *	LH-ALTH 101K-1-FI *	100	40	420	ball bearing	140	100 x 85	80 x 60	9	45
LH-ALTH 101K-1-CO *	BH-ALTH 101K-1-CO *	LH-ALTH 101K-1-FI-CO *	100	40	420	ball bearing	140	100 x 85	80 x 60	9	45
LH-ALTH 100K-3	BH-ALTH 100K-3	LH-ALTH 100K-3-FI	100	40	350	ball bearing	140	140 x 110	105 x 75–80	11	45
LH-ALTH 101K-3 *	BH-ALTH 101K-3 *	LH-ALTH 101K-3-FI *	100	40	420	ball bearing	140	140 x 110	105 x 75–80	11	45
LH-ALTH 101K-3-CO *	BH-ALTH 101K-3-CO *	LH-ALTH 101K-3-FI-CO *	100	40	420	ball bearing	140	140 x 110	105 x 75–80	11	45
LH-ALTH 125K-1	BH-ALTH 125K-1	LH-ALTH 125K-1-FI	125	40	550	ball bearing	165	100 x 85	80 x 60	9	45
LH-ALTH 125K-1-CO	BH-ALTH 125K-1-CO	LH-ALTH 125K-1-FI-CO	125	40	550	ball bearing	165	100 x 85	80 x 60	9	45
LH-ALTH 125K-3	BH-ALTH 125K-3	LH-ALTH 125K-3-FI	125	40	550	ball bearing	165	140 x 110	105 x 75–80	11	45
LH-ALTH 125K-3-CO	BH-ALTH 125K-3-CO	LH-ALTH 125K-3-FI-CO	125	40	550	ball bearing	165	140 x 110	105 x 75–80	11	45
LH-ALTH 127K	BH-ALTH 127K	LH-ALTH 127K-FI	125	54	750	ball bearing	170	140 x 110	105 x 75–80	11	55
LH-ALTH 150K	BH-ALTH 150K	LH-ALTH 150K-FI	150	50	650	ball bearing	197	140 x 110	105 x 75–80	11	65
LH-ALTH 152K *	BH-ALTH 152K *	LH-ALTH 152K-FI *	150	54	900	ball bearing	197	140 x 110	105 x 75–80	11	65
LH-ALTH 160K	BH-ALTH 160K	LH-ALTH 160K-FI	160	50	750	ball bearing	202	140 x 110	105 x 75–80	11	65
LH-ALTH 160K-CO	BH-ALTH 160K-CO	LH-ALTH 160K-FI-CO	160	50	750	ball bearing	202	140 x 110	105 x 75–80	11	65
LH-ALTH 162K *	BH-ALTH 162K *	LH-ALTH 162K-FI *	160	50	900	ball bearing	202	140 x 110	105 x 75–80	11	65
LH-ALTH 180K	BH-ALTH 180K	LH-ALTH 180K-FI	180	50	700	ball bearing	223	140 x 110	105 x 75–80	11	67
LH-ALTH 200K	BH-ALTH 200K	LH-ALTH 200K-FI	200	50	800	ball bearing	245	140 x 110	105 x 75–80	11	70
LH-ALTH 200K-CO	BH-ALTH 200K-CO	LH-ALTH 200K-FI-CO	200	50	800	ball bearing	245	140 x 110	105 x 75–80	11	70
LH-ALTH 202K *	BH-ALTH 202K *	LH-ALTH 202K-FI *	200	50	900	ball bearing	245	140 x 110	105 x 75–80	11	70
LH-ALTH 250K	BH-ALTH 250K	**	250	60	900	ball bearing	295	140 x 110	105 x 75–80	11	82
LH-ALTH 252K *	BH-ALTH 252K *	**	250	60	900	ball bearing	295	140 x 110	105 x 75–80	11	82

* Heavy-duty wheel version

** "stop-top" brake version, see versions / options

Versions / options***



	version with extremely crowned tread	version with heavy duty wheel centre, reinforced design	antistatic version, non-marking grey	with "stop-top" brake	with "central-stop" central brake system	with "ideal-stop" brake total height +17 mm	with directional lock (separate) 1x 360°
Technical description page	55		50	112	113	112	115
Product code suffix	-CO		-AS	-ST	-CS13	-IS	see ****
Available for			all	all	wheel Ø 160+200 mm	wheel Ø 160+200 mm****	for wheel Ø and plate dimensions, see****

*** Additional versions / options: with steel foot guard (-FS), available for wheel Ø 100–250 mm

**** Synthetic adapter plate to balance out total height for swivel and fixed castors without "ideal-stop" brake: product code AP3-17

***** RI-04.01 for wheel Ø 80–125 mm with plate 100x85 mm, RI-04.03 for wheel Ø 100–125x40 mm with plate 140x110 mm, RI-05.03 for wheel Ø 125x54–200 mm (Only for swivel castors without brake or swivel castor with "stop-top" and "central-stop" brake upon request)

LHZ-ALTH series

Pressed steel castors, heavy-duty design, with stem, wheel with Blickle Extrathane® polyurethane tread

750–900 kg

Bracket: LHZ series

- strong pressed steel, zinc-plated, blue-passivated, Cr6-free
- heavy fork and top plate
- double ball bearing in the swivel head
- very strong, welded steel plug-in stem, bolted and secured
- particularly resistant to shocks and impact due to **four specially-shaped, hardened bearing seats**

Wheel: ALTH series

- tread: high-quality polyurethane elastomer Blickle Extrathane®, hardness 92 Shore A, colour light brown, non-marking, non-staining
- wheel centre: die-cast aluminium, colour silver grey

Additional details:

- bracket series: page 92
- brakes: page 112–113
- wheel series: page 274
- bearing types: page 84–85

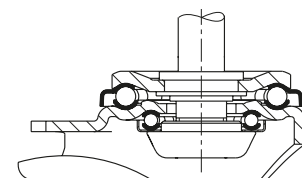

Swivel castors	Swivel castors with "stop-fix" brake	Wheel Ø [mm]	Wheel width [mm]	Load capacity [kg]	Bearing type	Total height [mm]	Stem Ø [mm]	Stem length [mm]	Offset swivel castor [mm]
LHZ-ALTH 127K	LHZ-ALTH 127K-FI	125	54	750	ball bearing	170	27	60	55
LHZ-ALTH 160K	LHZ-ALTH 160K-FI	160	50	750	ball bearing	202	27	60	65
LHZ-ALTH 160K-CO	LHZ-ALTH 160K-FI-CO	160	50	750	ball bearing	202	27	60	65
LHZ-ALTH 162K *	LHZ-ALTH 162K-FI *	160	50	900	ball bearing	202	27	60	65
LHZ-ALTH 200K	LHZ-ALTH 200K-FI	200	50	800	ball bearing	245	27	60	70
LHZ-ALTH 200K-CO	LHZ-ALTH 200K-FI-CO	200	50	800	ball bearing	245	27	60	70
LHZ-ALTH 202K *	LHZ-ALTH 202K-FI *	200	50	900	ball bearing	245	27	60	70

* Heavy-duty wheel version

Versions / options



	version with extremely crowned tread	version with heavy duty wheel centre, reinforced design	antistatic version, non-marking grey	with "stop-top" brake	with steel foot guard
Technical description page	55		50	112	116
Product code suffix	-CO		-AS	-ST	-FS
Available for			all	all	upon request

LUH-ALTH, BH-ALTH series

Pressed steel castors, heavy-duty design, enclosed, with top plate, wheel with Blickle Extrathane® polyurethane tread

650–1,000 kg

Bracket: LUH/BH series

- strong pressed steel, zinc-plated, blue-passivated, Cr6-free

Swivel bracket:

- four-point ball bearing for extremely heavy loads
- enclosed and sealed swivel head
- particularly resistant to shocks and impact due to **specialty-shaped, hardened bearing seats**

Wheel: ALTH series

- tread: high-quality polyurethane elastomer Blickle Extrathane®, hardness 92 Shore A, colour light brown, non-marking, non-staining
- wheel centre: die-cast aluminium, colour silver grey

Additional details:

- bracket series: page 93
- brakes: page 112–113
- wheel series: page 274
- bearing types: page 84–85



5

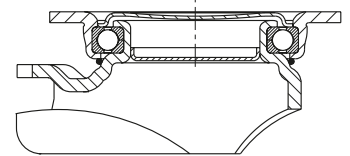

Swivel castors	Fixed castors	Swivel castors with "stop-fix" brake	Wheel Ø [mm]	Wheel width [mm]	Load capacity [kg]	Bearing type	Total height [mm]	Plate size [mm]	Bolt hole spacing [mm]	Bolt hole Ø [mm]	Offset swivel castor [mm]
LUH-ALTH 127K	BH-ALTH 127K	LUH-ALTH 127K-FI	125	54	750	ball bearing	170	140 x 110	105 x 75–80	11	55
LUH-ALTH 150K	BH-ALTH 150K	LUH-ALTH 150K-FI	150	50	650	ball bearing	197	140 x 110	105 x 75–80	11	61
LUH-ALTH 152K *	BH-ALTH 152K *	LUH-ALTH 152K-FI *	150	54	900	ball bearing	197	140 x 110	105 x 75–80	11	61
LUH-ALTH 160K	BH-ALTH 160K	LUH-ALTH 160K-FI	160	50	750	ball bearing	202	140 x 110	105 x 75–80	11	61
LUH-ALTH 160K-CO	BH-ALTH 160K-CO	LUH-ALTH 160K-FI-CO	160	50	750	ball bearing	202	140 x 110	105 x 75–80	11	61
LUH-ALTH 162K *	BH-ALTH 162K *	LUH-ALTH 162K-FI *	160	50	950	ball bearing	202	140 x 110	105 x 75–80	11	61
LUH-ALTH 200K	BH-ALTH 200K	LUH-ALTH 200K-FI	200	50	800	ball bearing	245	140 x 110	105 x 75–80	11	63
LUH-ALTH 200K-CO	BH-ALTH 200K-CO	LUH-ALTH 200K-FI-CO	200	50	800	ball bearing	245	140 x 110	105 x 75–80	11	63
LUH-ALTH 202K *	BH-ALTH 202K *	LUH-ALTH 202K-FI *	200	50	1,000	ball bearing	245	140 x 110	105 x 75–80	11	63

* Heavy-duty wheel version

Versions / options



	version with extremely crowned tread	version with heavy duty wheel centre, reinforced design	antistatic version, non-marking grey	directional lock (separate) 1 x 360°	with steel foot guard
Technical description page	55		50	115	116
Product code suffix	-CO		-AS	RI-05.03	-FS
Available for			all	all**	upon request

** Only for swivel castors without brake

LO-ALTH, BO-ALTH series

**Welded steel heavy-duty castors,
wheel with polyurethane tread
Blickle Extrathane®**

650–1,200 kg

Bracket: LO/BO series

- solid welded steel construction, zinc-plated, blue-passivated, Cr6-free

Swivel bracket:

- double ball bearing in the swivel head
- **four specially-shaped, hardened bearing seats** for additional strength
- bolted and secured welded central kingpin, extremely strong
- swivel head seal with labyrinth design
- grease nipple

Wheel: ALTH series

- tread: high-quality polyurethane elastomer Blickle Extrathane®, hardness 92 Shore A, colour light brown, non-marking, non-staining
- wheel centre: die-cast aluminium, colour silver grey

Additional details:

- bracket series: page 93
- brakes: page 112–113
- wheel series: page 274
- bearing types: page 84–85

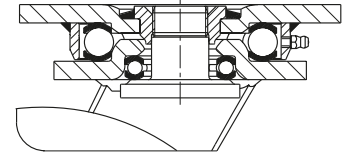

5

Swivel castors	Fixed castors	Swivel castor with "stop-top" brake	Wheel Ø [mm]	Wheel width [mm]	Load capacity [kg]	Bearing type	Total height [mm]	Plate size [mm]	Bolt hole spacing [mm]	Bolt hole Ø [mm]	Offset swivel castor [mm]
LO-ALTH 127K	BO-ALTH 127K	LO-ALTH 127K-ST	125	54	750	ball bearing	170	140 x 110	105 x 75–80	11	50
LO-ALTH 150K	BO-ALTH 150K	LO-ALTH 150K-ST	150	50	650	ball bearing	200	140 x 110	105 x 75–80	11	55
LO-ALTH 152K *	BO-ALTH 152K *	LO-ALTH 152K-ST *	150	54	900	ball bearing	200	140 x 110	105 x 75–80	11	55
LO-ALTH 160K	BO-ALTH 160K	LO-ALTH 160K-ST	160	50	750	ball bearing	205	140 x 110	105 x 75–80	11	55
LO-ALTH 160K-CO	BO-ALTH 160K-CO	LO-ALTH 160K-ST-CO	160	50	750	ball bearing	205	140 x 110	105 x 75–80	11	55
LO-ALTH 162K *	BO-ALTH 162K *	LO-ALTH 162K-ST *	160	50	950	ball bearing	205	140 x 110	105 x 75–80	11	55
LO-ALTH 200K	BO-ALTH 200K	LO-ALTH 200K-ST	200	50	800	ball bearing	245	140 x 110	105 x 75–80	11	60
LO-ALTH 200K-CO	BO-ALTH 200K-CO	LO-ALTH 200K-ST-CO	200	50	800	ball bearing	245	140 x 110	105 x 75–80	11	60
LO-ALTH 202K *	BO-ALTH 202K *	LO-ALTH 202K-ST *	200	50	1,000	ball bearing	245	140 x 110	105 x 75–80	11	60
LO-ALTH 250K	BO-ALTH 250K	LO-ALTH 250K-ST	250	60	1,000	ball bearing	295	140 x 110	105 x 75–80	11	70
LO-ALTH 252K *	BO-ALTH 252K *	LO-ALTH 252K-ST *	250	60	1,200	ball bearing	295	140 x 110	105 x 75–80	11	70

* Heavy-duty wheel version

Versions / options



	version with extremely crowned tread	version with heavy duty wheel centre, reinforced design	antistatic version, non-marking grey	with directional lock 4 x 90°	with steel foot guard	truck lock
Technical description page	55		50	115	116	114
Product code suffix	-CO		-AS	-RI4	-FS	FF 125 / 150 / 160 / 200
Available for			all	wheel Ø 125–200 mm	upon request	wheel Ø 125–200 mm

SETH series

Heavy-duty wheels
with **Blickle Extrathane®** polyurethane tread,
with **welded steel wheel centre**

500–1,350 kg

Tread and tyre hardness

92 Shore A

Smooth operation / floor preservation

good

Rolling resistance

very good

Wear resistance

excellent

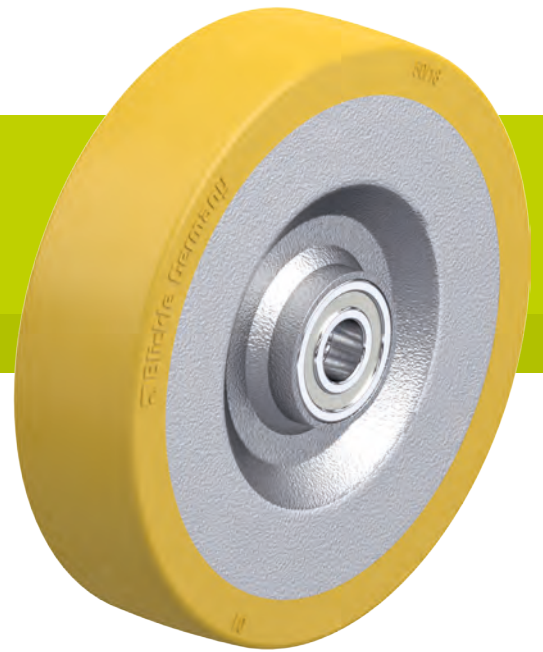

5

Tread:

- high-quality polyurethane elastomer Blickle Extrathane®, hardness 92 Shore A
- low rolling resistance
- high abrasion resistance
- high cut and tear propagation resistance
- colour light brown, non-marking, non-staining
- excellent chemical connection with the wheel centre

Wheel centre:

- thick-walled pressed steel, triple welded
- with welded tubular steel hub
- resistant to dirt, impact and shocks
- lacquered, colour silver

Other features:

- high chemical resistance to many aggressive substances
- operating temperature: -20 °C to +70 °C, temporarily up to +90 °C, reduced load capacity over +40 °C

Additional details:

- wheel series: page 66
- tread: page 55
- bearing types: page 84–85
- chemical resistance: page 51

Wheels	Wheel Ø (D) [mm]	Wheel width (T2) [mm]	Load capacity at 4 km/h [kg]	Load capacity at 10 km/h [kg]	Bearing type	Axle bore Ø (d) [mm]	Hub length (T1) [mm]
SETH 125/20K	125	50	500	250	ball bearing	20	60
SETH 150/20K	150	50	650	320	ball bearing	20	60
SETH 150/25K	150	50	650	320	ball bearing	25	60
SETH 160/20K	160	50	700	350	ball bearing	20	60
SETH 160/25K	160	50	700	350	ball bearing	25	60
SETH 200/20K	200	50	1,000	500	ball bearing	20	60
SETH 200/25K	200	50	1,000	500	ball bearing	25	60
SETH 250/25K	250	60	1,350	670	ball bearing	25	70

Versions / options

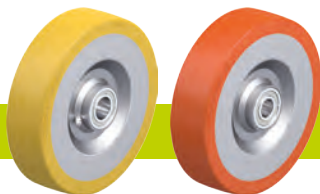

with grease nipple other shore hardnesses and special colours

Technical description page

Product code suffix **-NI**

Available for upon request upon request

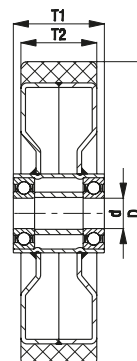

LH-SETH, BH-SETH series

Pressed steel castors, heavy-duty design, with top plate, wheel with Blickle Extrathane® polyurethane tread

500–900 kg

Bracket: LH/BH series

- strong pressed steel, zinc-plated, blue-passivated, Cr6-free
- heavy fork and top plate

Swivel bracket:

- double ball bearing in the swivel head
- bolted and secured central kingpin, extremely strong
- particularly resistant to shocks and impact due to **four specially-shaped, hardened bearing seats**

Wheel: SETH series

- tread: high-quality polyurethane elastomer Blickle Extrathane®, hardness 92 Shore A, colour light brown, non-marking, non-staining
- wheel centre: thick-walled pressed steel, triple welded, with tubular steel hub, lacquered, colour silver

Additional details:

- bracket series: page 92
- brakes: page 112–113
- wheel series: page 282
- bearing types: page 84–85

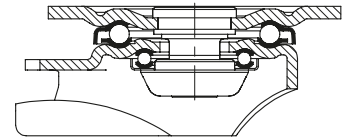

5

Swivel castors	Fixed castors	Swivel castors with "stop-fix" brake	Wheel Ø [mm]	Wheel width [mm]	Load capacity [kg]	Bearing type	Total height [mm]	Plate size [mm]	Bolt hole spacing [mm]	Bolt hole Ø [mm]	Offset swivel castor [mm]
LH-SETH 125K	BH-SETH 125K	LH-SETH 125K-FI	125	50	500	ball bearing	170	140 x 110	105 x 75–80	11	55
LH-SETH 150K	BH-SETH 150K	LH-SETH 150K-FI	150	50	650	ball bearing	197	140 x 110	105 x 75–80	11	65
LH-SETH 160K	BH-SETH 160K	LH-SETH 160K-FI	160	50	700	ball bearing	202	140 x 110	105 x 75–80	11	65
LH-SETH 200K	BH-SETH 200K	LH-SETH 200K-FI	200	50	900	ball bearing	245	140 x 110	105 x 75–80	11	70
LH-SETH 250K	BH-SETH 250K	*	250	60	900	ball bearing	295	140 x 110	105 x 75–80	11	82

* "stop-top" brake version, see versions / options

Versions / options



	with "stop-top" brake	with "ideal-stop" brake total height +17 mm	directional lock (separate) 1 x 360°	with steel foot guard	truck lock
Technical description page	112	112	115	116	114
Product code suffix	-ST	-IS	RI-05.03	-FS	FF 125 / 150 / 160 / 200
Available for	all	wheel Ø 160–200 mm**	wheel Ø 125–200 mm***	all	wheel Ø 125–200 mm

** Synthetic adapter plate to balance out total height for swivel and fixed castors without "ideal-stop" brake: **product code AP3-17**

*** Only for swivel castors without brake or swivel castor with "stop-top" brake upon request

LO-SETH, BO-SETH series

**Welded steel heavy-duty castors,
wheel with polyurethane tread
Blickle Extrathane®**

500–1,200 kg

Bracket: LO/BO series

- solid welded steel construction, zinc-plated, blue-passivated, Cr6-free

Swivel bracket:

- double ball bearing in the swivel head
- **four specially-shaped, hardened bearing seats** for additional strength
- bolted and secured welded central kingpin, extremely strong
- swivel head seal with labyrinth design
- grease nipple

Wheel: SETH series

- tread: high-quality polyurethane elastomer Blickle Extrathane®, hardness 92 Shore A, colour light brown, non-marking, non-staining
- wheel centre: thick-walled pressed steel, triple welded, with tubular steel hub, lacquered, colour silver

Additional details:

- bracket series: page 93
- brakes: page 112–113
- wheel series: page 282
- bearing types: page 84–85



5

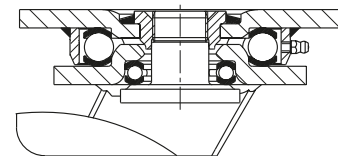

Swivel castors	Fixed castors	Swivel castor with "stop-top" brake	Wheel Ø [mm]	Wheel width [mm]	Load capacity [kg]	Bearing type	Total height [mm]	Plate size [mm]	Bolt hole spacing [mm]	Bolt hole Ø [mm]	Offset swivel castor [mm]
LO-SETH 125K	BO-SETH 125K	LO-SETH 125K-ST	125	50	500	ball bearing	170	140 x 110	105 x 75–80	11	50
LO-SETH 150K	BO-SETH 150K	LO-SETH 150K-ST	150	50	650	ball bearing	200	140 x 110	105 x 75–80	11	55
LO-SETH 160K	BO-SETH 160K	LO-SETH 160K-ST	160	50	700	ball bearing	205	140 x 110	105 x 75–80	11	55
LO-SETH 200K	BO-SETH 200K	LO-SETH 200K-ST	200	50	1,000	ball bearing	245	140 x 110	105 x 75–80	11	60
LO-SETH 250K	BO-SETH 250K	LO-SETH 250K-ST	250	60	1,200	ball bearing	295	140 x 110	105 x 75–80	11	70

Versions / options



	with directional lock 4 x 90°	with steel foot guard	truck lock
Technical description page	115	116	114
Product code suffix	-R14	-FS	FF 125 / 150 / 160 / 200
Available for	wheel Ø 125–200 mm	upon request	wheel Ø 125–200 mm

LS-SETH, BS-SETH series

**Welded steel heavy-duty castors,
heavy-duty swivel head, wheel with
Blickle Extrathane® polyurethane tread**

500–1,350 kg

Bracket: LS/BS series

- particularly robust welded steel construction, zinc-plated, yellow-passivated, Cr6-free

Swivel bracket:

- axial grooved ball bearing ISO 104 and tapered roller bearing ISO 355 in the swivel head
- bolted and secured welded central kingpin, extremely strong
- dust and splash-proof
- grease nipple

Wheel: SETH series

- tread: high-quality polyurethane elastomer Blickle Extrathane®, hardness 92 Shore A, colour light brown, non-marking, non-staining
- wheel centre: thick-walled pressed steel, triple welded, with tubular steel hub, lacquered, colour silver

Additional details:

- bracket series: page 94
- brakes: page 112–113
- wheel series: page 282
- bearing types: page 84–85

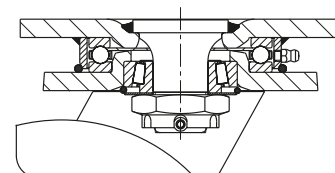

5

Swivel castors	Fixed castors	Swivel castor with "stop-top" brake	Wheel Ø [mm]	Wheel width [mm]	Load capacity [kg]	Bearing type	Total height [mm]	Plate size [mm]	Bolt hole spacing [mm]	Bolt hole Ø [mm]	Offset swivel castor [mm]
LS-SETH 125K	BS-SETH 125K	LS-SETH 125K-ST	125	50	500	ball bearing	170	140 x 110	105 x 75–80	11	50
LS-SETH 150K	BS-SETH 150K	LS-SETH 150K-ST	150	50	650	ball bearing	200	140 x 110	105 x 75–80	11	55
LS-SETH 160K	BS-SETH 160K	LS-SETH 160K-ST	160	50	700	ball bearing	205	140 x 110	105 x 75–80	11	55
LS-SETH 200K	BS-SETH 200K	LS-SETH 200K-ST	200	50	1,000	ball bearing	245	140 x 110	105 x 75–80	11	60
LS-SETH 250K	BS-SETH 250K	LS-SETH 250K-ST	250	60	1,350	ball bearing	305	175 x 140	140 x 105	14	75

Versions / options



	with directional lock 4 x 90°	with steel foot guard	truck lock
Technical description page	115	116	114
Product code suffix	-R14	-FS	FF 125 / 150 / 160 / 200
Available for	all	all	wheel Ø 125–200 mm

VSTH, GTH series, wheel Ø 35–200 mm

Heavy-duty wheels
with **Blickle Extrathane®** polyurethane tread,
with steel or cast iron wheel centre



100–1,600 kg

Tread and tyre hardness

92 Shore A

Smooth operation / floor preservation

good

Rolling resistance

very good

Wear resistance

excellent



Tread:

- high-quality polyurethane elastomer Blickle Extrathane®, hardness 92 Shore A
- low rolling resistance
- high abrasion resistance
- high cut and tear propagation resistance
- colour light brown, non-marking, non-staining
- excellent chemical connection with the wheel centre

Wheel centre:

- series VSTH: steel
- series GTH: rugged grey cast iron, with grease nipple from wheel Ø 150 mm, lacquered, colour silver

Other features:

- high chemical resistance to many aggressive substances
- operating temperature: -20 °C to +70 °C, temporarily up to +90 °C, reduced load capacity over +40 °C

Additional details:

- wheel series: page 66
- tread: page 55
- bearing types: page 84–85
- chemical resistance: page 51

Wheels	Wheel Ø (D) [mm]	Wheel width (T2) [mm]	Load capacity at 4 km/h [kg]	Load capacity at 10 km/h [kg]	Bearing type	Axle bore Ø (d) [mm]	Hub length (T1) [mm]
VSTH 35/6K	35	27	100	–	ball bearing	6	30
VSTH 50/8K	50	33	150	–	ball bearing	8	36
VSTH 60/15K	60	35	200	–	ball bearing	15	35
VSTH 62/10K	60	60	320	–	ball bearing	10	60
VSTH 65/15K	65	40	250	–	ball bearing	15	40
VSTH 75/20K	75	40	270	–	ball bearing	20	40
VSTH 80/20K	80	40	280	–	ball bearing	20	40
VSTH 82/20K	80	70	500	–	ball bearing	20	70
GTH 100/15K	100	40	450	–	ball bearing	15	40
GTH 101/20-50K	100	50	600	–	ball bearing	20	50
GTH 101/20K	100	50	600	–	ball bearing	20	60
GTH 125/15K	125	40	550	–	ball bearing	15	45
GTH 127/20-50K	125	50	700	350	ball bearing	20	50
GTH 127/20K	125	50	700	350	ball bearing	20	60
GTH 127/25-50K	125	50	700	350	ball bearing	25	50
GTH 140/20K	140	54	900	450	ball bearing	20	60
GTH 150/20-50K	150	50	800	400	ball bearing	20	50
GTH 150/20K	150	50	800	400	ball bearing	20	60
GTH 160/20K	160	50	800	400	ball bearing	20	60
GTH 160/25K	160	50	800	400	ball bearing	25	60
GTH 175/20K	175	50	875	430	ball bearing	20	60
GTH 175/25K	175	50	875	430	ball bearing	25	60
GTH 177/25K	175	80	1,300	650	ball bearing	25	80
GTH 181/25K	180	40	800	400	ball bearing	25	40
GTH 182/25K	180	65	1,100	550	ball bearing	25	75
GTH 200/20K	200	50	1,000	500	ball bearing	20	60
GTH 200/25K	200	50	1,000	500	ball bearing	25	60
GTH 201/25K	200	60	1,400	700	ball bearing	25	60
GTH 202/25K	200	80	1,600	800	ball bearing	25	90
GTH 202/30K	200	80	1,600	800	ball bearing	30	90
GTH 202/35K	200	80	1,600	800	ball bearing	35	90

For other wheel Ø, see next page

Versions / options

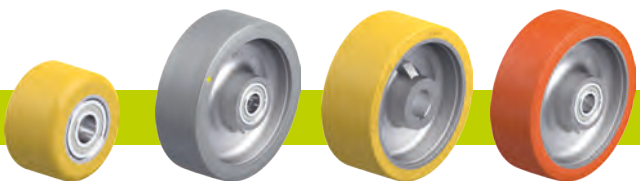
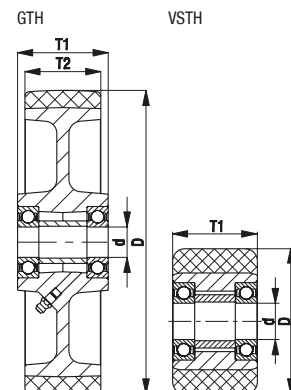

image VSTH	antistatic version, non-marking grey	drive wheels with hub keyway	other shore hardnesses and special colours
Technical description page	50	75	
Product code suffix	-AS	GTHN series	
Available for	upon request	see page 541–542	upon request



GTH series, wheel Ø 250–1,000 mm

Heavy-duty wheels
with **Blickle Extrathane®** polyurethane tread,
with **cast iron wheel centre**



1,250–30,000 kg

Tread and tyre hardness
 92 Shore A

Smooth operation / floor preservation
 good

Rolling resistance
 very good

Wear resistance
 excellent



- Tread:**
- high-quality polyurethane elastomer Blickle Extrathane®, hardness 92 Shore A
 - low rolling resistance
 - high abrasion resistance
 - high cut and tear propagation resistance
 - colour light brown, non-marking, non-staining
 - excellent chemical connection with the wheel centre

- Wheel centre:**
- rugged grey cast iron
 - with grease nipple
 - lacquered, colour silver

- Other features:**
- high chemical resistance to many aggressive substances
 - operating temperature: -20 °C to +70 °C, temporarily up to +90 °C, reduced load capacity over +40 °C

- Additional details:**
- wheel series: page 66
 - tread: page 55
 - bearing types: page 84–85
 - chemical resistance: page 51

Wheels	Wheel Ø (D) [mm]	Wheel width (T2) [mm]	Load capacity at 4 km/h [kg]	Load capacity at 10 km/h [kg]	Bearing type	Axle bore Ø (d) [mm]	Hub length (T1) [mm]
GTH 251/25K	250	50	1,250	620	ball bearing	25	60
GTH 251/30K	250	50	1,250	620	ball bearing	30	60
GTH 250/25K	250	60	1,500	750	ball bearing	25	70
GTH 250/30K	250	60	1,500	750	ball bearing	30	70
GTH 250/30K-01	250	60	1,750	870	ball bearing	30	70
GTH 250/35K	250	60	1,500	750	ball bearing	35	70
GTH 252/25K	250	80	1,800	900	ball bearing	25	90
GTH 252/30K	250	80	2,200	1,100	ball bearing	30	90
GTH 254/40K	250	130	3,150	1,550	ball bearing	40	140
GTH 301/25K	300	45	1,300	650	ball bearing	25	60
GTH 300/30K	300	60	1,800	900	ball bearing	30	70
GTH 302/30K	300	80	2,400	1,200	ball bearing	30	90
GTH 302/35K	300	80	2,400	1,200	ball bearing	35	90
GTH 304/35K	300	100	3,000	1,500	ball bearing	35	120
GTH 360/40K	360	75	2,500	1,250	ball bearing	40	90
GTH 362/40K	360	80	3,000	1,500	ball bearing	40	90
GTH 363/40K	360	100	3,600	1,800	ball bearing	40	100
GTH 364/40K	360	120	3,800	1,900	ball bearing	40	120
GTH 400/35K	400	60	2,400	1,200	ball bearing	35	75
GTH 402/40K	400	80	3,000	1,500	ball bearing	40	90
GTH 404/40K	400	100	3,800	1,900	ball bearing	40	120
GTH 406/50K	400	125	5,000	2,500	ball bearing	50	125
GTH 500/50K	500	100	5,000	2,500	ball bearing	50	100
GTH 504/60K	500	150	7,500	3,750	ball bearing	60	150
GTH 506/80K	500	200	10,000	5,000	ball bearing	80	200
GTH 602/80K	600	150	9,000	4,500	ball bearing	80	150
GTH 604/80K	600	200	12,000	6,000	ball bearing	80	200
GTH 750/120K	750	200	15,000	7,500	ball bearing	120	200
GTH 1000/160PR	1,000	300	30,000	15,000	spherical roller bearing	160	330

Other dimensions available upon request

Versions / options



	antistatic version, non-marking grey	drive wheels with hub keyway	other shore hardnesses and special colours
Technical description page	50	75	
Product code suffix	-AS	GTHN series	
Available for	upon request	see page 541–542	upon request

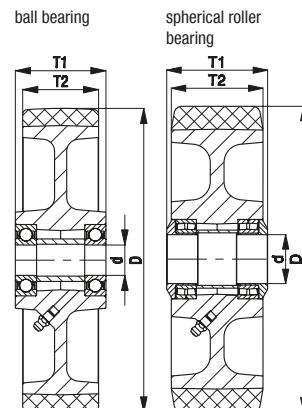

LH-VSTH, BH-VSTH, LH-GTH, BH-GTH series

Pressed steel castors, heavy-duty design, with top plate, wheel with Blickle Extrathane® polyurethane tread



280–900 kg

Bracket: LH/BH series

- strong pressed steel, zinc-plated, blue-passivated, Cr6-free
- heavy fork and top plate

Swivel bracket:

- double ball bearing in the swivel head
- bolted and secured central kingpin, extremely strong
- particularly resistant to shocks and impact due to **four specially-shaped, hardened bearing seats**

Wheel: VSTH/GTH series

- tread: high-quality polyurethane elastomer Blickle Extrathane®, hardness 92 Shore A, colour light brown, non-marking, non-staining
- wheel centre: VSTH series: steel
GTH series: rugged grey cast iron, with grease nipple from wheel Ø 150 mm, lacquered, colour silver

Additional details:

- bracket series: page 92
- brakes: page 112–113
- wheel series: page 286–287
- bearing types: page 84–85



5

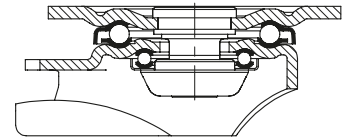

Swivel castors	Fixed castors	Swivel castors with "stop-fix" brake	Wheel Ø [mm]	Wheel width [mm]	Load capacity [kg]	Bearing type	Total height [mm]	Plate size [mm]	Bolt hole spacing [mm]	Bolt hole Ø [mm]	Offset swivel castor [mm]
LH-VSTH 62K			60	60	320	ball bearing	92	100 x 85	80 x 60	9	45
LH-VSTH 80K	BH-VSTH 80K	LH-VSTH 80K-FI	80	40	280	ball bearing	120	100 x 85	80 x 60	9	45
LH-VSTH 82K			80	70	500	ball bearing	112	100 x 85	80 x 60	9	45
LH-GTH 100K-1	BH-GTH 100K-1	LH-GTH 100K-1-FI	100	40	450	ball bearing	140	100 x 85	80 x 60	9	45
LH-GTH 100K-3	BH-GTH 100K-3	LH-GTH 100K-3-FI	100	40	450	ball bearing	140	140 x 110	105 x 75–80	11	45
LH-GTH 125K-1	BH-GTH 125K-1	LH-GTH 125K-1-FI	125	40	550	ball bearing	165	100 x 85	80 x 60	9	45
LH-GTH 125K-3	BH-GTH 125K-3	LH-GTH 125K-3-FI	125	40	550	ball bearing	165	140 x 110	105 x 75–80	11	45
LH-GTH 127K	BH-GTH 127K	LH-GTH 127K-FI	125	50	700	ball bearing	170	140 x 110	105 x 75–80	11	55
LH-GTH 150K	BH-GTH 150K	LH-GTH 150K-FI	150	50	800	ball bearing	197	140 x 110	105 x 75–80	11	65
LH-GTH 160K	BH-GTH 160K	LH-GTH 160K-FI	160	50	800	ball bearing	202	140 x 110	105 x 75–80	11	65
LH-GTH 175K	BH-GTH 175K	LH-GTH 175K-FI	175	50	875	ball bearing	220	140 x 110	105 x 75–80	11	67
LH-GTH 200K	BH-GTH 200K	LH-GTH 200K-FI	200	50	900	ball bearing	245	140 x 110	105 x 75–80	11	70
LH-GTH 202K	BO-GTH 202K *	**	200	80	800	ball bearing	245	140 x 110	105 x 75–80	11	70
LH-GTH 250K	BH-GTH 250K	**	250	60	900	ball bearing	295	140 x 110	105 x 75–80	11	82

* Welded steel construction

** "stop-top" brake version, see versions / options

Versions / options



	antistatic version, non-marking grey	with "stop-top" brake	with "central-stop" central brake system	with "ideal-stop" brake total height +17 mm	with directional lock (separate) 1x 360°	with steel foot guard	truck lock
Technical description page	50	112	113	112	115	116	114
Product code suffix	-AS	-ST	-CS13	-IS	see ****	-FS	FF 125 / 150 / 160 / 200
Available for	upon request	wheel Ø 80x40, 100–250 mm	wheel Ø 160, 200x50 mm	wheel Ø 160+200 mm***	for wheel Ø and plate dimensions, see****	wheel Ø 100–250 mm	wheel Ø 125x50–200 mm

*** Synthetic adapter plate to balance out total height for swivel and fixed castors without "ideal-stop" brake: **product code AP3-17**

**** **RI-04.01** for wheel Ø 80x40, 100, 125 mm with plate 100x85 mm, **RI-04.03** for wheel Ø 100–125x40 mm with plate 140x110 mm, **RI-05.03** for wheel Ø 125x50–200x50 mm (Only for swivel castors without brake or swivel castor with "stop-top" and "central-stop" brake upon request)

LUH-GTH, BH-GTH series

Pressed steel castors, heavy-duty design, enclosed, with top plate, wheel with Blickle Extrathane® polyurethane tread

700–1,000 kg

Bracket: LUH/BH series

- strong pressed steel, zinc-plated, blue-passivated, Cr6-free

Swivel bracket:

- four-point ball bearing for extremely heavy loads
- enclosed and sealed swivel head
- particularly resistant to shocks and impact due to **specially-shaped, hardened bearing seats**

Wheel: GTH series

- tread: high-quality polyurethane elastomer Blickle Extrathane®, hardness 92 Shore A, colour light brown, non-marking, non-staining
- wheel centre: rugged grey cast iron, with grease nipple from wheel Ø 150 mm, lacquered, colour silver

Additional details:

- bracket series: page 93
- brakes: page 112–113
- wheel series: page 286
- bearing types: page 84–85

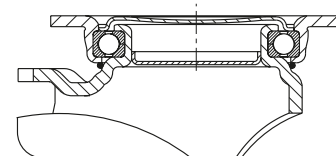

5

Swivel castors	Fixed castors	Swivel castors with "stop-fix" brake	Wheel Ø [mm]	Wheel width [mm]	Load capacity [kg]	Bearing type	Total height [mm]	Plate size [mm]	Bolt hole spacing [mm]	Bolt hole Ø [mm]	Offset swivel castor [mm]
LUH-GTH 127K	BH-GTH 127K	LUH-GTH 127K-FI	125	50	700	ball bearing	170	140 x 110	105 x 75–80	11	55
LUH-GTH 150K	BH-GTH 150K	LUH-GTH 150K-FI	150	50	800	ball bearing	197	140 x 110	105 x 75–80	11	61
LUH-GTH 160K	BH-GTH 160K	LUH-GTH 160K-FI	160	50	800	ball bearing	202	140 x 110	105 x 75–80	11	61
LUH-GTH 200K	BH-GTH 200K	LUH-GTH 200K-FI	200	50	1,000	ball bearing	245	140 x 110	105 x 75–80	11	63

Versions / options



	antistatic version, non-marking grey	directional lock (separate) 1 x 360°	with steel foot guard
Technical description page	50	115	116
Product code suffix	-AS	RI-05.03	-FS
Available for	upon request	all*	upon request

* Only for swivel castors without brake

LO-GTH, BO-GTH series

**Welded steel heavy-duty castors,
wheel with polyurethane tread
Blickle Extrathane®**

700–1,250 kg

Bracket: LO/BO series

- solid welded steel construction, zinc-plated, blue-passivated, Cr6-free

Swivel bracket:

- double ball bearing in the swivel head
- **four specially-shaped, hardened bearing seats** for additional strength
- bolted and secured welded central kingpin, extremely strong
- swivel head seal with labyrinth design
- grease nipple

Wheel: GTH series

- tread: high-quality polyurethane elastomer Blickle Extrathane®, hardness 92 Shore A, colour light brown, non-marking, non-staining
- wheel centre: rugged grey cast iron, with grease nipple from wheel Ø 150 mm, lacquered, colour silver

Additional details:

- bracket series: page 93
- brakes: page 112–113
- wheel series: page 286–287
- bearing types: page 84–85



5

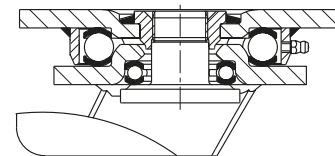

Swivel castors	Fixed castors	Swivel castor with "stop-top" brake	Wheel Ø [mm]	Wheel width [mm]	Load capacity [kg]	Bearing type	Total height [mm]	Plate size [mm]	Bolt hole spacing [mm]	Bolt hole Ø [mm]	Offset swivel castor [mm]
LO-GTH 127K	BO-GTH 127K	LO-GTH 127K-ST	125	50	700	ball bearing	170	140 x 110	105 x 75–80	11	50
LO-GTH 150K	BO-GTH 150K	LO-GTH 150K-ST	150	50	800	ball bearing	200	140 x 110	105 x 75–80	11	55
LO-GTH 160K	BO-GTH 160K	LO-GTH 160K-ST	160	50	800	ball bearing	205	140 x 110	105 x 75–80	11	55
LO-GTH 200K	BO-GTH 200K	LO-GTH 200K-ST	200	50	1,000	ball bearing	245	140 x 110	105 x 75–80	11	60
LO-GTH 201K	BO-GTH 201K	LO-GTH 201K-ST	200	60	1,250	ball bearing	245	140 x 110	105 x 75–80	11	60
LO-GTH 202K	BO-GTH 202K	LO-GTH 202K-ST	200	80	1,100	ball bearing	245	140 x 110	105 x 75–80	11	65
LO-GTH 251K	BO-GTH 251K	LO-GTH 251K-ST	250	50	1,200	ball bearing	295	140 x 110	105 x 75–80	11	70
LO-GTH 250K	BO-GTH 250K	LO-GTH 250K-ST	250	60	1,200	ball bearing	295	140 x 110	105 x 75–80	11	70

Versions / options



	antistatic version, non-marking grey	with directional lock 4 x 90°	with steel foot guard	truck lock
Technical description page	50	115	116	114
Product code suffix	-AS	-RI4	-FS	FF 125 / 150 / 160 / 200
Available for	upon request	wheel Ø 125–200x60 mm	upon request	wheel Ø 125–200 mm

LS-GTH, BS-GTH series

Welded steel heavy-duty castors, heavy-duty swivel head, wheel with Blickle Extrathane® polyurethane tread

700–12,000 kg

Bracket: LS/BS series

- particularly robust welded steel construction, zinc-plated, yellow-passivated, Cr6-free
- Swivel bracket:
 - axial grooved ball bearing ISO 104 and tapered roller bearing ISO 355 in the swivel head
 - bolted and secured welded central kingpin, extremely strong
 - dust and splash-proof
 - grease nipple

Wheel: GTH series

- tread: high-quality polyurethane elastomer Blickle Extrathane®, hardness 92 Shore A, colour light brown, non-marking, non-staining
- wheel centre: rugged grey cast iron, with grease nipple from wheel Ø 150 mm, lacquered, colour silver

Additional details:

- bracket series: page 94
- brakes: page 112–113
- wheel series: page 286–287
- bearing types: page 84–85

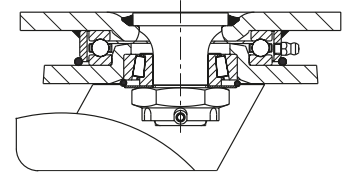

5

Swivel castors	Fixed castors	Swivel castor with "stop-top" brake	Wheel Ø [mm]	Wheel width [mm]	Load capacity [kg]	Bearing type	Total height [mm]	Plate size [mm]	Bolt hole spacing [mm]	Bolt hole Ø [mm]	Offset swivel castor [mm]
LS-GTH 127K	BS-GTH 127K	LS-GTH 127K-ST	125	50	700	ball bearing	170	140 x 110	105 x 75–80	11	50
LS-GTH 150K	BS-GTH 150K	LS-GTH 150K-ST	150	50	800	ball bearing	200	140 x 110	105 x 75–80	11	55
LS-GTH 160K	BS-GTH 160K	LS-GTH 160K-ST	160	50	800	ball bearing	205	140 x 110	105 x 75–80	11	55
LS-GTH 200K	BS-GTH 200K	LS-GTH 200K-ST	200	50	1,000	ball bearing	245	140 x 110	105 x 75–80	11	60
LS-GTH 201K	BS-GTH 201K	LS-GTH 201K-ST	200	60	1,400	ball bearing	245	140 x 110	105 x 75–80	11	60
LS-GTH 202K	BS-GTH 202K	LS-GTH 202K-ST	200	80	1,600	ball bearing	255	175 x 140	140 x 105	14	65
LS-GTH 250K	BS-GTH 250K	LS-GTH 250K-ST	250	60	1,500	ball bearing	305	175 x 140	140 x 105	14	75
LS-GTH 252K	BS-GTH 252K	LS-GTH 252K-ST	250	80	1,800	ball bearing	305	175 x 140	140 x 105	14	75
LS-GTH 300K	BS-GTH 300K	LS-GTH 300K-ST	300	60	1,800	ball bearing	355	175 x 140	140 x 105	14	85
LS-GTH 302K	BS-GTH 302K	LS-GTH 302K-ST	300	80	2,400	ball bearing	355	175 x 140	140 x 105	14	85
LS-GTH 304K	BS-GTH 304K	*	300	100	3,000	ball bearing	370	200 x 160	160 x 120	14	85
LS-GTH 360K	BS-GTH 360K	*	360	75	2,500	ball bearing	430	200 x 160	160 x 120	14	100
LS-GTH 364K	BS-GTH 364K	*	360	120	3,800	ball bearing	430	255 x 200	210 x 160	18	100
LS-GTH 402K	BS-GTH 402K	*	400	80	3,000	ball bearing	470	200 x 160	160 x 120	14	100
LS-GTH 406K	BS-GTH 406K	*	400	125	5,000	ball bearing	480	255 x 200	210 x 160	18	125
LS-GTH 504K	BS-GTH 504K	*	500	150	7,500	ball bearing	630	400 x 300	340 x 240	26	125
LS-GTH 604K	BS-GTH 604K	*	600	200	12,000	ball bearing	730	400 x 300	340 x 240	26	130

* "Radstop" brake version

Versions / options



	antistatic version, non-marking grey	with "Radstop" wheel brake	with directional lock 4 x 90°	with directional lock 4 x 90° (inserted by hand)	with steel foot guard	truck lock
Technical description page	50	113	115	115	116	114
Product code suffix	-AS	-RAH	-RI4	-RI4H	-FS	FF 125 / 150 / 160 / 200
Available for	upon request	from wheel Ø 300x100 mm upon request	wheel Ø 125–300x80 mm	from wheel Ø 300x100 mm upon request	wheel Ø 125–250 mm	wheel Ø 125–200x60 mm

LOD-VSTH, -ALTH, -GTH, BOD-VSTH, -ALTH, -GTH series

Welded steel twin wheel heavy-duty castors, wheels with polyurethane tread
Blickle Extrathane®



500–900 kg

Bracket: LOD/BOD series

- solid welded steel construction, zinc-plated, blue-passivated, Cr6-free

Swivel bracket:

- double ball bearing in the swivel head
- **four specially-shaped, hardened bearing seats** for additional strength
- bolted and secured welded central kingpin, extremely strong
- swivel head seal with labyrinth design
- grease nipple

Wheel: VSTH/ALTH/GTH series

- tread: high-quality polyurethane elastomer Blickle Extrathane®, hardness 92 Shore A, colour light brown, non-marking, non-staining
- wheel centre: VSTH series: steel
ALTH series: die-cast aluminium
GTH series: rugged grey cast iron, lacquered, colour silver

Additional details:

- bracket series: page 93
- wheel series: page 274, 286
- bearing types: page 84–85



5

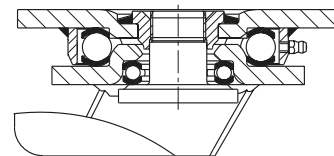

Swivel castors	Fixed castors	Wheel Ø [mm]	Wheel width [mm]	Load capacity [kg]	Bearing type	Total height [mm]	Plate size [mm]	Bolt hole spacing [mm]	Bolt hole Ø [mm]	Offset swivel castor [mm]
LOD-VSTH 75K	BOD-VSTH 75K	75	2 x 40	500	ball bearing	123	140 x 110	105 x 75–80	11	40
LOD-ALTH 101K	BOD-ALTH 101K	100	2 x 40	750	ball bearing	145	140 x 110	105 x 75–80	11	45
LOD-GTH 125K	BOD-GTH 125K	125	2 x 40	900	ball bearing	170	140 x 110	105 x 75–80	11	50

Fixed castors: long side of plate parallel to the wheel axle

Versions / options



antistatic version, non-marking grey	with steel foot guard
Technical description page	50 / 116
Product code suffix	-AS / -FS
Available for	upon request / upon request

LSD-VSTH, BSD-VSTH, LSD-GTH, BSD-GTH series

Welded steel heavy-duty twin wheel castors, heavy-duty swivel head, wheels with Blickle Extrathane® polyurethane tread

520–12,000 kg

Bracket: LSD/BSD series

- particularly robust welded steel construction, zinc-plated, yellow-passivated, Cr6-free

Swivel bracket:

- axial grooved ball bearing ISO 104 and tapered roller bearing ISO 355 in the swivel head
- bolted and secured welded central kingpin, extremely strong
- dust and splash-proof
- grease nipple

Wheel: VSTH/GTH series

- tread: high-quality polyurethane elastomer Blickle Extrathane®, hardness 92 Shore A, colour light brown, non-marking, non-staining

wheel centre:

- VSTH series: steel
- GTH series: rugged grey cast iron, with grease nipple from wheel Ø 150 mm, lacquered, colour silver

Additional details:

- bracket series: page 94
- brakes: page 112–113
- wheel series: page 286–287
- bearing types: page 84–85

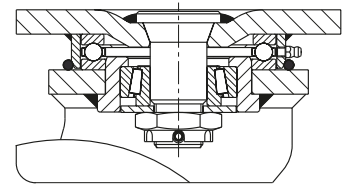
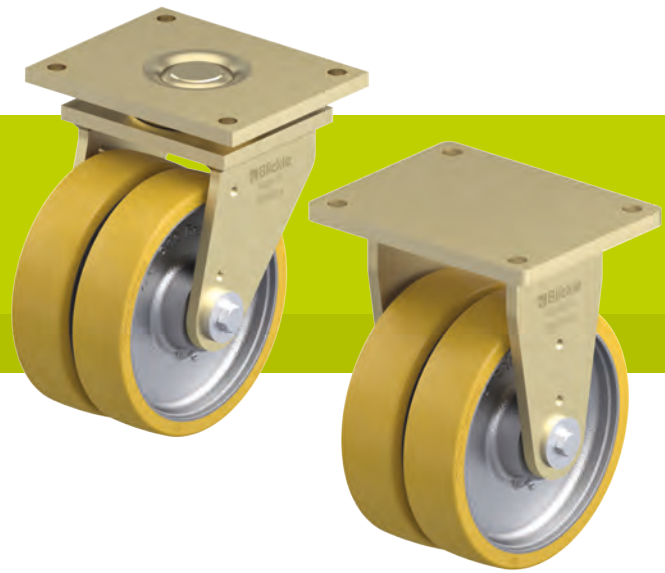

5

Swivel castors	Fixed castors	Wheel Ø [mm]	Wheel width [mm]	Load capacity [kg]	Bearing type	Total height [mm]	Plate size [mm]	Bolt hole spacing [mm]	Bolt hole Ø [mm]	Offset swivel castor [mm]
LSD-VSTH 80K	BSD-VSTH 80K	80	2 x 40	520	ball bearing	125	140 x 110	105 x 75–80	11	40
LSD-GTH 100K	BSD-GTH 100K	100	2 x 40	810	ball bearing	145	140 x 110	105 x 75–80	11	45
LSD-GTH 127K	BSD-GTH 127K	125	2 x 50	1,250	ball bearing	185	175 x 140	140 x 105	14	50
LSD-GTH 150K-35	BSD-GTH 150K-35	150	2 x 50	1,400	ball bearing	215	175 x 140	140 x 105	14	55
LSD-GTH 200K-35	BSD-GTH 200K-35	200	2 x 50	1,800	ball bearing	260	175 x 140	140 x 105	14	60
LSD-GTH 202K	BSD-GTH 202K	200	2 x 80	2,850	ball bearing	280	255 x 200	210 x 160	18	60
LSD-GTH 250K	BSD-GTH 250K	250	2 x 60	2,700	ball bearing	330	255 x 200	210 x 160	18	70
LSD-GTH 252K	BSD-GTH 252K	250	2 x 80	3,700	ball bearing	330	255 x 200	210 x 160	18	70
LSD-GTH 302K	BSD-GTH 302K	300	2 x 80	4,300	ball bearing	390	255 x 200	210 x 160	18	80
LSD-GTH 304K	BSD-GTH 304K	300	2 x 100	5,400	ball bearing	390	255 x 200	210 x 160	18	80
	BSD-GTH 304K	300	2 x 100	5,400	ball bearing	390	300 x 200	210 x 160	18	–
LSD-GTH 360K	BSD-GTH 360K	360	2 x 75	4,500	ball bearing	450	255 x 200	210 x 160	18	90
LSD-GTH 404K-42	BSD-GTH 404K-42	400	2 x 100	6,800	ball bearing	530	400 x 300	340 x 240	26	125
LSD-GTH 504K	BSD-GTH 504K	500	2 x 150	12,000	ball bearing	630	400 x 300	340 x 240	26	125

Fixed castors: long side of plate parallel to the wheel axle

Versions / options



	antistatic version, non-marking grey	with "Radstop" wheel brake	with "Radstop" wheel brake	with directional lock 4 x 90°	with directional lock 4 x 90° (inserted by hand)	with steel foot guard
Technical description page	50	113	113	115	115	116
Product code suffix	-AS	-RA	-RAH	-RI4	-RI4H	-FS
Available for	upon request	up to wheel Ø 200x50 mm upon request	from wheel Ø 200x80 mm upon request	wheel Ø 80–200x50 mm upon request	from wheel Ø 200x80 mm upon request	upon request

ALST series

Heavy-duty wheels
with **Blickle Softhane®** polyurethane tread,
with aluminium wheel centre



200–1,150 kg

Tread and tyre hardness

75 Shore A

Smooth operation / floor preservation

very good

Rolling resistance

very good

Wear resistance

very good



Tread:

- high-quality polyurethane elastomer Blickle Softhane®, hardness 75 Shore A
- extra-thick elastic tread for excellent operational comfort
- very good floor preservation, low-noise operation
- low rolling resistance
- high abrasion resistance
- high cut and tear propagation resistance
- colour green, non-marking, non-staining
- excellent chemical connection with the wheel centre

Wheel centre:

- die-cast aluminium

Other features:

- high chemical resistance to many aggressive substances
- operating temperature: -20 °C to +70 °C, temporarily up to +90 °C, reduced load capacity over +40 °C

Additional details:

- wheel series: page 66
- tread: page 55
- bearing types: page 84–85
- chemical resistance: page 51

Wheels	Wheel Ø (D) [mm]	Wheel width (T2) [mm]	Load capacity at 4 km/h [kg]	Load capacity at 10 km/h [kg]	Bearing type	Axle bore Ø (d) [mm]	Hub length (T1) [mm]
ALST 80/15K	80	30	200	–	ball bearing	15	35
ALST 82/15K	80	40	230	–	ball bearing	15	40
ALST 100/15K	100	40	320	–	ball bearing	15	40
ALST 125/15K	125	40	370	–	ball bearing	15	45
ALST 127/20K	125	54	450	180	ball bearing	20	60
ALST 150/20K	150	50	500	200	ball bearing	20	60
ALST 160/20K	160	50	580	230	ball bearing	20	60
ALST 180/20K	180	50	670	260	ball bearing	20	60
ALST 200/20K	200	50	750	300	ball bearing	20	60
ALST 250/20K	250	50	850	340	ball bearing	20	60
ALST 250/25K	250	50	850	340	ball bearing	25	60
ALST 300/25K	300	60	1,150	460	ball bearing	25	70

5

Versions / options

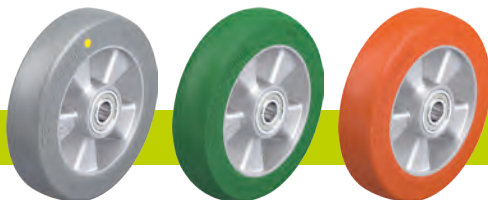

antistatic version, non-marking grey	with extremely crowned tread	other shore hardnesses and special colours
--------------------------------------	------------------------------	--

Technical description page	50	55	
Product code suffix	-AS	-CO	
Available for	wheel Ø 100, 125, 150, 160, 200 mm	upon request	upon request

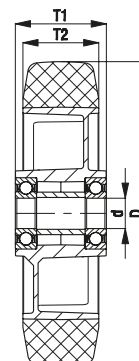

L-ALST, B-ALST, BH-ALST series

Pressed steel castors, medium-duty version, with top plate, wheel with Blickle Softhane® polyurethane tread

200–500 kg

Bracket: L/B/BH series

- pressed steel, zinc-plated, blue-passivated, Cr6-free

Swivel bracket:

- double ball bearing in the swivel head
- strong central kingpin (from wheel Ø 150 mm)
- swivel head seal
- minimum swivel head play and smooth rolling characteristic and increased service life due to the special dynamic Blickle riveting process

Wheel: ALST series

- tread: high-quality polyurethane elastomer Blickle Softhane®, hardness 75 Shore A, colour green, non-marking, non-staining
- wheel centre: die-cast aluminium, colour silver grey

Additional details:

- bracket series: page 91
- brakes: page 112–113
- wheel series: page 294
- bearing types: page 84–85

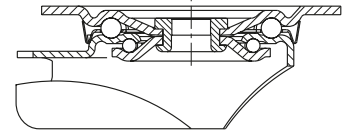

5

Swivel castors	Fixed castors	Swivel castors with "stop-fix" brake	Wheel Ø [mm]	Wheel width [mm]	Load capacity [kg]	Bearing type	Total height [mm]	Plate size [mm]	Bolt hole spacing [mm]	Bolt hole Ø [mm]	Offset swivel castor [mm]
L-ALST 80K	B-ALST 80K	L-ALST 80K-FI	80	30	200	ball bearing	102	100 x 85	80 x 60	9	38
L-ALST 100K	B-ALST 100K	L-ALST 100K-FI	100	40	250	ball bearing	125	100 x 85	80 x 60	9	36
L-ALST 125K	B-ALST 125K	L-ALST 125K-FI	125	40	250	ball bearing	150	100 x 85	80 x 60	9	38
L-ALST 150K	B-ALST 150K	L-ALST 150K-FI	150	50	400	ball bearing	190	140 x 110	105 x 75–80	11	60
L-ALST 160K	B-ALST 160K	L-ALST 160K-FI	160	50	400	ball bearing	195	140 x 110	105 x 75–80	11	60
L-ALST 180K	B-ALST 180K	L-ALST 180K-FI	180	50	400	ball bearing	215	140 x 110	105 x 75–80	11	60
L-ALST 200K	B-ALST 200K	L-ALST 200K-FI	200	50	400	ball bearing	235	140 x 110	105 x 75–80	11	65
L-ALST 250K-3	BH-ALST 250K	*	250	50	500	ball bearing	295	140 x 110	105 x 75–80	11	77

* "stop-top" brake version, see versions / options

Versions / options



	antistatic version, non-marking grey	with extremely crowned tread	with "stop-top" brake	with "central-stop" central brake system	directional lock (separate) 1 x 360°	directional lock (separate) 1 x 360°	with steel foot guard
Technical description page	50	55	112	113	115	115	116
Product code suffix	-AS	-CO	-ST	-CS11	RI-03.01	RI-05.03	-FS
Available for	wheel Ø 100, 125, 150, 160, 200 mm	upon request	all	wheel Ø 160+200 mm	wheel Ø 100–125 mm**	wheel Ø 150–200 mm**	wheel Ø 100–250 mm

** Only for swivel castors without brake or swivel castor with "stop-top" and "central-stop" brake upon request

LK-ALST, BK-ALST, BH-ALST series

Pressed steel castors, heavy-duty design, with top plate, wheel with Blickle Softhane® polyurethane tread

230–600 kg

Bracket: LK/BK/BH series

- strong pressed steel, zinc-plated, blue-passivated, Cr6-free

Swivel bracket:

- double ball bearing in the swivel head
- strong central kingpin (from wheel Ø 125x50 mm)
- swivel head seal
- minimum swivel head play and smooth rolling characteristic and increased service life due to the special dynamic Blickle riveting process

Wheel: ALST series

- tread: high-quality polyurethane elastomer Blickle Softhane®, hardness 75 Shore A, colour green, non-marking, non-staining
- wheel centre: die-cast aluminium, colour silver grey

Additional details:

- bracket series: page 92
- brakes: page 112–113
- wheel series: page 294
- bearing types: page 84–85



5

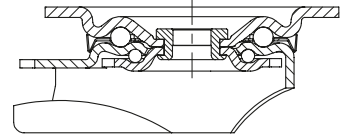

Swivel castors	Fixed castors	Swivel castors with "stop-fix" brake	Wheel Ø [mm]	Wheel width [mm]	Load capacity [kg]	Bearing type	Total height [mm]	Plate size [mm]	Bolt hole spacing [mm]	Bolt hole Ø [mm]	Offset swivel castor [mm]
LK-ALST 82K	BK-ALST 82K	LK-ALST 82K-FI	80	40	230	ball bearing	110	100 x 85	80 x 60	9	40
LK-ALST 100K-1	BK-ALST 100K-1	LK-ALST 100K-1-FI	100	40	320	ball bearing	130	100 x 85	80 x 60	9	45
LK-ALST 100K-3	BK-ALST 100K-3	LK-ALST 100K-3-FI	100	40	320	ball bearing	130	140 x 110	105 x 75–80	11	45
LK-ALST 125K-1	BK-ALST 125K-1	LK-ALST 125K-1-FI	125	40	350	ball bearing	155	100 x 85	80 x 60	9	48
LK-ALST 125K-3	BK-ALST 125K-3	LK-ALST 125K-3-FI	125	40	350	ball bearing	155	140 x 110	105 x 75–80	11	48
LK-ALST 127K	BH-ALST 127K	LK-ALST 127K-FI	125	54	450	ball bearing	170	140 x 110	105 x 75–80	11	55
LK-ALST 150K	BH-ALST 150K	LK-ALST 150K-FI	150	50	500	ball bearing	197	140 x 110	105 x 75–80	11	60
LK-ALST 160K	BH-ALST 160K	LK-ALST 160K-FI	160	50	580	ball bearing	202	140 x 110	105 x 75–80	11	60
LK-ALST 180K	BH-ALST 180K	LK-ALST 180K-FI	180	50	600	ball bearing	223	140 x 110	105 x 75–80	11	65
LK-ALST 200K	BH-ALST 200K	LK-ALST 200K-FI	200	50	600	ball bearing	245	140 x 110	105 x 75–80	11	62

Versions / options



	antistatic version, non-marking grey	with extremely crowned tread	with "stop-top" brake	with "central-stop" central brake system	with "ideal-stop" brake total height +17 mm	with directional lock (separate) 1x 360°	with steel foot guard
Technical description page	50	55	112	113	112	115	116
Product code suffix	-AS	-CO	-ST	-CS11	-IS	see *	-FS
Available for	wheel Ø 100, 125, 150, 160, 200 mm	upon request	all	wheel Ø 100–125x40 mm	Ø 100, 125, 160, 200 mm with plate 140x110	for wheel Ø and plate dimensions, see*	upon request

* RI-05.01 for wheel Ø 80–125 mm with plate 100x85 mm, RI-03.03 for wheel Ø 100–125x40 mm with plate 140x110 mm, RI-05.03 for wheel Ø 125x54–200 mm (Only for swivel castors without brake or swivel castor with "stop-top" and "central-stop" brake upon request)

LKR-ALST series

Pressed steel castors, heavy-duty design, with bolt hole, wheel with Blickle Softhane® polyurethane tread



230–350 kg

Bracket: LKR series

- strong pressed steel, zinc-plated, blue-passivated, Cr6-free
- double ball bearing in the swivel head
- strong central kingpin
- minimum swivel head play and smooth rolling characteristic and increased service life due to the special dynamic Blickle riveting process

Wheel: ALST series

- tread: high-quality polyurethane elastomer Blickle Softhane®, hardness 75 Shore A, colour green, non-marking, non-staining
- wheel centre: die-cast aluminium, colour silver grey

Additional details:

- bracket series: page 92
- brakes: page 112–113
- wheel series: page 294
- bearing types: page 84–85

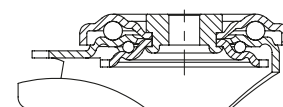

5

Swivel castors	Swivel castors with "stop-fix" brake	Wheel Ø [mm]	Wheel width [mm]	Load capacity [kg]	Bearing type	Total height [mm]	Plate Ø [mm]	Bolt hole Ø [mm]	Offset swivel castor [mm]
LKR-ALST 82K	LKR-ALST 82K-FI	80	40	230	ball bearing	110	88	13	40
LKR-ALST 100K	LKR-ALST 100K-FI	100	40	320	ball bearing	130	88	13	45
LKR-ALST 125K	LKR-ALST 125K-FI	125	40	350	ball bearing	155	88	13	48

Versions / options



	antistatic version, non-marking grey	with extremely crowned tread	truck lock
Technical description page	50	55	114
Product code suffix	-AS	-CO	FF 100-1 / FF 125-1
Available for	wheel Ø 100–125 mm	upon request	wheel Ø 100+125 mm

LH-ALST, BH-ALST series

Pressed steel castors, heavy-duty design, with top plate, wheel with **Blickle Softhane® polyurethane tread**

230–850 kg



Bracket: LH/BH series

- strong pressed steel, zinc-plated, blue-passivated, Cr6-free
- heavy fork and top plate

Swivel bracket:

- double ball bearing in the swivel head
- bolted and secured central kingpin, extremely strong
- particularly resistant to shocks and impact due to **four specially-shaped, hardened bearing seats**

Wheel: ALST series

- tread: high-quality polyurethane elastomer **Blickle Softhane®**, hardness 75 Shore A, colour green, non-marking, non-staining
- wheel centre: die-cast aluminium, colour silver grey

Additional details:

- bracket series: page 92
- brakes: page 112–113
- wheel series: page 294
- bearing types: page 84–85



5

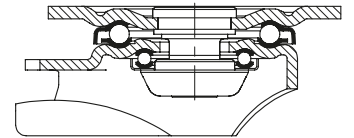

Swivel castors	Fixed castors	Swivel castors with "stop-fix" brake	Wheel Ø [mm]	Wheel width [mm]	Load capacity [kg]	Bearing type	Total height [mm]	Plate size [mm]	Bolt hole spacing [mm]	Bolt hole Ø [mm]	Offset swivel castor [mm]
LH-ALST 82K	BH-ALST 82K	LH-ALST 82K-FI	80	40	230	ball bearing	120	100 x 85	80 x 60	9	45
LH-ALST 100K-1	BH-ALST 100K-1	LH-ALST 100K-1-FI	100	40	320	ball bearing	140	100 x 85	80 x 60	9	45
LH-ALST 100K-3	BH-ALST 100K-3	LH-ALST 100K-3-FI	100	40	320	ball bearing	140	140 x 110	105 x 75–80	11	45
LH-ALST 125K-1	BH-ALST 125K-1	LH-ALST 125K-1-FI	125	40	370	ball bearing	165	100 x 85	80 x 60	9	45
LH-ALST 125K-3	BH-ALST 125K-3	LH-ALST 125K-3-FI	125	40	370	ball bearing	165	140 x 110	105 x 75–80	11	45
LH-ALST 127K	BH-ALST 127K	LH-ALST 127K-FI	125	54	450	ball bearing	170	140 x 110	105 x 75–80	11	55
LH-ALST 150K	BH-ALST 150K	LH-ALST 150K-FI	150	50	500	ball bearing	197	140 x 110	105 x 75–80	11	65
LH-ALST 160K	BH-ALST 160K	LH-ALST 160K-FI	160	50	580	ball bearing	202	140 x 110	105 x 75–80	11	65
LH-ALST 180K	BH-ALST 180K	LH-ALST 180K-FI	180	50	670	ball bearing	223	140 x 110	105 x 75–80	11	67
LH-ALST 200K	BH-ALST 200K	LH-ALST 200K-FI	200	50	750	ball bearing	245	140 x 110	105 x 75–80	11	70
LH-ALST 250K	BH-ALST 250K	*	250	50	850	ball bearing	295	140 x 110	105 x 75–80	11	82

* "stop-top" brake version, see versions / options

Versions / options



	antistatic version, non-marking grey	with extremely crowned tread	with "stop-top" brake	with "central-stop" central brake system	with "ideal-stop" brake total height +17 mm	with directional lock (separate) 1x 360°	with steel foot guard
Technical description page	50	55	112	113	112	115	116
Product code suffix	-AS	-CO	-ST	-CS13	-IS	see ***	-FS
Available for	wheel Ø 100, 125, 150, 160, 200 mm	upon request	all	wheel Ø 160+200 mm	wheel Ø 160+200 mm**	for wheel Ø and plate dimensions, see***	from wheel Ø 100 mm

** Synthetic adapter plate to balance out total height for swivel and fixed castors without "ideal-stop" brake: **product code AP3-17**

*** **RI-04.01** for wheel Ø 80–125 mm with plate 100x85 mm, **RI-04.03** for wheel Ø 100–125x40 mm with plate 140x110 mm, **RI-05.03** for wheel Ø 125x54–200 mm (Only for swivel castors without brake or swivel castor with "stop-top" and "central-stop" brake upon request)

LUH-ALST, BH-ALST series

Pressed steel castors, heavy-duty design, enclosed, with top plate, wheel with Blickle Softhane® polyurethane tread

450–750 kg

Bracket: LUH/BH series

- strong pressed steel, zinc-plated, blue-passivated, Cr6-free

Swivel bracket:

- four-point ball bearing for extremely heavy loads
- enclosed and sealed swivel head
- particularly resistant to shocks and impact due to **specially-shaped, hardened bearing seats**

Wheel: ALST series

- tread: high-quality polyurethane elastomer Blickle Softhane®, hardness 75 Shore A, colour green, non-marking, non-staining
- wheel centre: die-cast aluminium, colour silver grey

Additional details:

- bracket series: page 93
- brakes: page 112–113
- wheel series: page 294
- bearing types: page 84–85

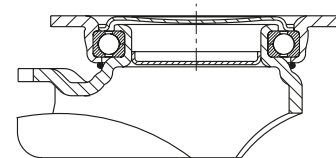

5

Swivel castors	Fixed castors	Swivel castors with "stop-fix" brake	Wheel Ø [mm]	Wheel width [mm]	Load capacity [kg]	Bearing type	Total height [mm]	Plate size [mm]	Bolt hole spacing [mm]	Bolt hole Ø [mm]	Offset swivel castor [mm]
LUH-ALST 127K	BH-ALST 127K	LUH-ALST 127K-FI	125	54	450	ball bearing	170	140 x 110	105 x 75–80	11	55
LUH-ALST 150K	BH-ALST 150K	LUH-ALST 150K-FI	150	50	500	ball bearing	197	140 x 110	105 x 75–80	11	61
LUH-ALST 160K	BH-ALST 160K	LUH-ALST 160K-FI	160	50	580	ball bearing	202	140 x 110	105 x 75–80	11	61
LUH-ALST 200K	BH-ALST 200K	LUH-ALST 200K-FI	200	50	750	ball bearing	245	140 x 110	105 x 75–80	11	63

Versions / options



	antistatic version, non-marking grey	with extremely crowned tread	directional lock (separate) 1 x 360°	with steel foot guard
Technical description page	50	55	115	116
Product code suffix	-AS	-CO	RI-05.03	-FS
Available for	all	upon request	all*	upon request

* Only for swivel castors without brake

LO-ALST, BO-ALST series

**Welded steel heavy-duty castors,
wheel with polyurethane tread
Blickle Softhane®**

450–850 kg

Bracket: LO/BO series

- solid welded steel construction, zinc-plated, blue-passivated, Cr6-free

Swivel bracket:

- double ball bearing in the swivel head
- **four specially-shaped, hardened bearing seats** for additional strength
- bolted and secured welded central kingpin, extremely strong
- swivel head seal with labyrinth design
- grease nipple

Wheel: ALST series

- tread: high-quality polyurethane elastomer Blickle Softhane®, hardness 75 Shore A, colour green, non-marking, non-staining
- wheel centre: die-cast aluminium, colour silver grey

Additional details:

- bracket series: page 93
- brakes: page 112–113
- wheel series: page 294
- bearing types: page 84–85



5

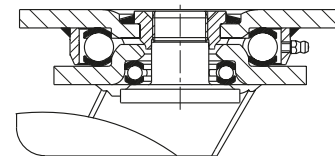

Swivel castors	Fixed castors	Swivel castor with "stop-top" brake	Wheel Ø [mm]	Wheel width [mm]	Load capacity [kg]	Bearing type	Total height [mm]	Plate size [mm]	Bolt hole spacing [mm]	Bolt hole Ø [mm]	Offset swivel castor [mm]
LO-ALST 127K	BO-ALST 127K	LO-ALST 127K-ST	125	54	450	ball bearing	170	140 x 110	105 x 75–80	11	50
LO-ALST 150K	BO-ALST 150K	LO-ALST 150K-ST	150	50	500	ball bearing	200	140 x 110	105 x 75–80	11	55
LO-ALST 160K	BO-ALST 160K	LO-ALST 160K-ST	160	50	580	ball bearing	205	140 x 110	105 x 75–80	11	55
LO-ALST 200K	BO-ALST 200K	LO-ALST 200K-ST	200	50	750	ball bearing	245	140 x 110	105 x 75–80	11	60
LO-ALST 250K	BO-ALST 250K	LO-ALST 250K-ST	250	50	850	ball bearing	295	140 x 110	105 x 75–80	11	70

Versions / options



	antistatic version, non-marking grey	with extremely crowned tread	with directional lock 4 x 90°	with steel foot guard	truck lock
Technical description page	50	55	115	116	114
Product code suffix	-AS	-CO	-RI4	-FS	FF 125 / 150 / 160 / 200
Available for	wheel Ø 125–200 mm	upon request	wheel Ø 125–200 mm	upon request	wheel Ø 125–200 mm

GST series

Heavy-duty wheels
with **Blickle Softhane®** polyurethane tread,
with cast iron wheel centre

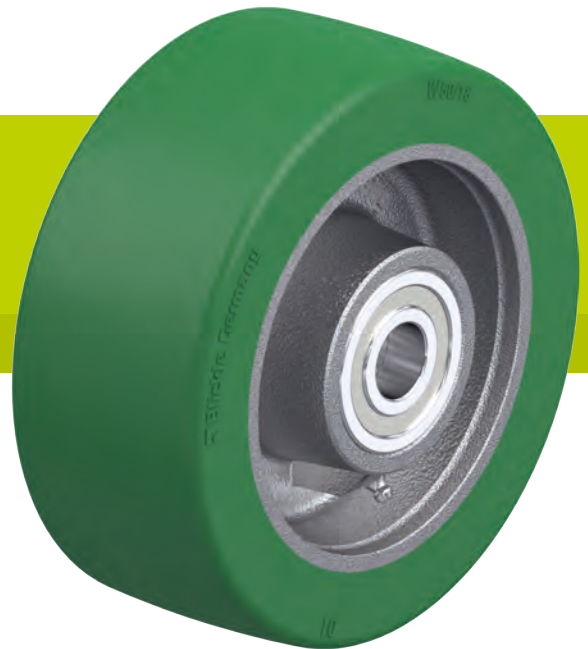

450–3,000 kg

Tread and tyre hardness
 75 Shore A

Smooth operation / floor preservation
 very good

Rolling resistance
 very good

Wear resistance
 very good



Tread:

- high-quality polyurethane elastomer Blickle Softhane®, hardness 75 Shore A
- extra-thick elastic tread for excellent operational comfort
- very good floor preservation, low-noise operation
- low rolling resistance
- high abrasion resistance
- high cut and tear propagation resistance
- colour green, non-marking, non-staining
- excellent chemical connection with the wheel centre

Wheel centre:

- rugged grey cast iron
- with grease nipple from wheel Ø 160 mm
- lacquered, colour silver

Other features:

- high chemical resistance to many aggressive substances
- operating temperature: -20 °C to +70 °C, temporarily up to +90 °C, reduced load capacity over +40 °C

Additional details:

- wheel series: page 67
- tread: page 55
- bearing types: page 84–85
- chemical resistance: page 51

Wheels	Wheel Ø (D) [mm]	Wheel width (T2) [mm]	Load capacity at 4 km/h [kg]	Load capacity at 10 km/h [kg]	Bearing type	Axle bore Ø (d) [mm]	Hub length (T1) [mm]
GST 127/20K	125	50	450	180	ball bearing	20	60
GST 150/20K	150	50	570	220	ball bearing	20	60
GST 160/20K	160	50	600	240	ball bearing	20	60
GST 200/20K	200	50	800	320	ball bearing	20	60
GST 200/25K	200	50	800	320	ball bearing	25	60
GST 202/25K	200	80	1,200	480	ball bearing	25	90
GST 202/35K	200	80	1,200	480	ball bearing	35	90
GST 250/25K	250	60	1,200	480	ball bearing	25	70
GST 250/35K	250	60	1,200	480	ball bearing	35	70
GST 252/25K	250	80	1,400	560	ball bearing	25	90
GST 252/30K	250	80	1,400	560	ball bearing	30	90
GST 302/30K	300	80	1,800	680	ball bearing	30	90
GST 302/35K	300	80	1,800	680	ball bearing	35	90
GST 304/35K	300	100	2,250	840	ball bearing	35	120
GST 404/40K	400	100	3,000	1,100	ball bearing	40	120

5

Versions / options



	antistatic version, non-marking grey	drive wheels with hub keyway	hub fitting wheels	other shore hardnesses and special colours
Technical description page	50	76	77	
Product code suffix	-AS	GSTN series	GSTA series	
Available for	upon request	see page 543	see page 551	upon request

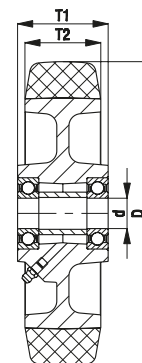

LH-GST, BH-GST series

Pressed steel castors, heavy-duty design, with top plate, wheel with Blickle Softhane® polyurethane tread

450–900 kg

Bracket: LH/BH series

- strong pressed steel, zinc-plated, blue-passivated, Cr6-free
- heavy fork and top plate

Swivel bracket:

- double ball bearing in the swivel head
- bolted and secured central kingpin, extremely strong
- particularly resistant to shocks and impact due to **four specially-shaped, hardened bearing seats**

Wheel: GST series

- tread: high-quality polyurethane elastomer Blickle Softhane®, hardness 75 Shore A, colour green, non-marking, non-staining
- wheel centre: rugged grey cast iron, with grease nipple from wheel Ø 160 mm, lacquered, colour silver

Additional details:

- bracket series: page 92
- brakes: page 112–113
- wheel series: page 301
- bearing types: page 84–85



5

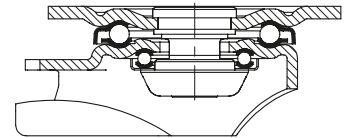

Swivel castors	Fixed castors	Swivel castors with "stop-fix" brake	Wheel Ø [mm]	Wheel width [mm]	Load capacity [kg]	Bearing type	Total height [mm]	Plate size [mm]	Bolt hole spacing [mm]	Bolt hole Ø [mm]	Offset swivel castor [mm]
LH-GST 127K	BH-GST 127K	LH-GST 127K-FI	125	50	450	ball bearing	170	140 x 110	105 x 75–80	11	55
LH-GST 150K	BH-GST 150K	LH-GST 150K-FI	150	50	570	ball bearing	197	140 x 110	105 x 75–80	11	65
LH-GST 160K	BH-GST 160K	LH-GST 160K-FI	160	50	600	ball bearing	202	140 x 110	105 x 75–80	11	65
LH-GST 200K	BH-GST 200K	LH-GST 200K-FI	200	50	800	ball bearing	245	140 x 110	105 x 75–80	11	70
LH-GST 202K	BO-GST 202K *	**	200	80	800	ball bearing	245	140 x 110	105 x 75–80	11	70
LH-GST 250K	BH-GST 250K	**	250	60	900	ball bearing	295	140 x 110	105 x 75–80	11	82

* Welded steel construction

** "stop-top" brake version, see versions / options

Versions / options



	antistatic version, non-marking grey	with "stop-top" brake	with "central-stop" central brake system	with "ideal-stop" brake total height +17 mm	directional lock (separate) 1 x 360°	with steel foot guard	truck lock
Technical description page	50	112	113	112	115	116	114
Product code suffix	-AS	-ST	-CS13	-IS	RI-05.03	-FS	FF 125 / 150 / 160 / 200
Available for	upon request	all	wheel Ø 160+200x50 mm	wheel Ø 160–200 mm****	wheel Ø 125–200x50 mm****	all	wheel Ø 125–200 mm

*** Synthetic adapter plate to balance out total height for swivel and fixed castors without "ideal-stop" brake: **product code AP3-17**

**** Only for swivel castors without brake or swivel castor with "stop-top" and "central-stop" brake upon request

LUH-GST, BH-GST series

Pressed steel castors, heavy-duty design, enclosed, with top plate, wheel with Blickle Softhane® polyurethane tread

450–800 kg

Bracket: LUH/BH series

- strong pressed steel, zinc-plated, blue-passivated, Cr6-free

Swivel bracket:

- four-point ball bearing for extremely heavy loads
- enclosed and sealed swivel head
- particularly resistant to shocks and impact due to **specialty-shaped, hardened bearing seats**

Wheel: GST series

- tread: high-quality polyurethane elastomer Blickle Softhane®, hardness 75 Shore A, colour green, non-marking, non-staining
- wheel centre: rugged grey cast iron, with grease nipple from wheel Ø 160 mm, lacquered, colour silver

Additional details:

- bracket series: page 93
- brakes: page 112–113
- wheel series: page 301
- bearing types: page 84–85

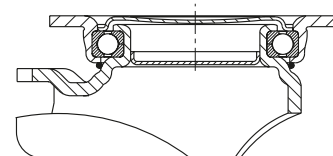

5

Swivel castors	Fixed castors	Swivel castors with "stop-fix" brake	Wheel Ø [mm]	Wheel width [mm]	Load capacity [kg]	Bearing type	Total height [mm]	Plate size [mm]	Bolt hole spacing [mm]	Bolt hole Ø [mm]	Offset swivel castor [mm]
LUH-GST 127K	BH-GST 127K	LUH-GST 127K-FI	125	50	450	ball bearing	170	140 x 110	105 x 75–80	11	55
LUH-GST 150K	BH-GST 150K	LUH-GST 150K-FI	150	50	570	ball bearing	197	140 x 110	105 x 75–80	11	61
LUH-GST 160K	BH-GST 160K	LUH-GST 160K-FI	160	50	600	ball bearing	202	140 x 110	105 x 75–80	11	61
LUH-GST 200K	BH-GST 200K	LUH-GST 200K-FI	200	50	800	ball bearing	245	140 x 110	105 x 75–80	11	63

Versions / options



	antistatic version, non-marking grey	directional lock (separate) 1 x 360°	with steel foot guard
Technical description page	50	115	116
Product code suffix	-AS	RI-05.03	-FS
Available for	upon request	all*	upon request

* Only for swivel castors without brake

LO-GST, BO-GST series

**Welded steel heavy-duty castors,
wheel with polyurethane tread
Blickle Softhane®**

450–1,200 kg

Bracket: LO/BO series

- solid welded steel construction, zinc-plated, blue-passivated, Cr6-free

Swivel bracket:

- double ball bearing in the swivel head
- **four specially-shaped, hardened bearing seats** for additional strength
- bolted and secured welded central kingpin, extremely strong
- swivel head seal with labyrinth design
- grease nipple

Wheel: GST series

- tread: high-quality polyurethane elastomer Blickle Softhane®, hardness 75 Shore A, colour green, non-marking, non-staining
- wheel centre: rugged grey cast iron, with grease nipple from wheel Ø 160 mm, lacquered, colour silver

Additional details:

- bracket series: page 93
- brakes: page 112–113
- wheel series: page 301
- bearing types: page 84–85



5

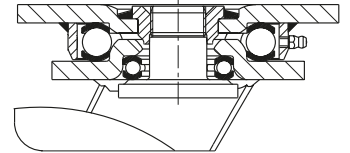

Swivel castors	Fixed castors	Swivel castor with "stop-top" brake	Wheel Ø [mm]	Wheel width [mm]	Load capacity [kg]	Bearing type	Total height [mm]	Plate size [mm]	Bolt hole spacing [mm]	Bolt hole Ø [mm]	Offset swivel castor [mm]
LO-GST 127K	BO-GST 127K	LO-GST 127K-ST	125	50	450	ball bearing	170	140 x 110	105 x 75–80	11	50
LO-GST 150K	BO-GST 150K	LO-GST 150K-ST	150	50	570	ball bearing	200	140 x 110	105 x 75–80	11	55
LO-GST 160K	BO-GST 160K	LO-GST 160K-ST	160	50	600	ball bearing	205	140 x 110	105 x 75–80	11	55
LO-GST 200K	BO-GST 200K	LO-GST 200K-ST	200	50	800	ball bearing	245	140 x 110	105 x 75–80	11	60
LO-GST 202K	BO-GST 202K	LO-GST 202K-ST	200	80	1,100	ball bearing	245	140 x 110	105 x 75–80	11	65
LO-GST 250K	BO-GST 250K	LO-GST 250K-ST	250	60	1,200	ball bearing	295	140 x 110	105 x 75–80	11	70

Versions / options



	antistatic version, non-marking grey	with directional lock 4 x 90°	with steel foot guard	truck lock
Technical description page	50	115	116	114
Product code suffix	-AS	-RI4	-FS	FF 125 / 150 / 160 / 200
Available for	upon request	wheel Ø 125–200x50 mm	upon request	wheel Ø 125–200 mm

LS-GST, BS-GST series

Welded steel heavy-duty castors, heavy-duty swivel head, wheel with Blickle Softhane® polyurethane tread

450–2,250 kg

Bracket: LS/BS series

- particularly robust welded steel construction, zinc-plated, yellow-passivated, Cr6-free
- Swivel bracket:
 - axial grooved ball bearing ISO 104 and tapered roller bearing ISO 355 in the swivel head
 - bolted and secured welded central kingpin, extremely strong
 - dust and splash-proof
 - grease nipple

Wheel: GST series

- tread: high-quality polyurethane elastomer Blickle Softhane®, hardness 75 Shore A, colour green, non-marking, non-staining
- wheel centre: rugged grey cast iron, with grease nipple from wheel Ø 160 mm, lacquered, colour silver

Additional details:

- bracket series: page 94
- brakes: page 112–113
- wheel series: page 301
- bearing types: page 84–85

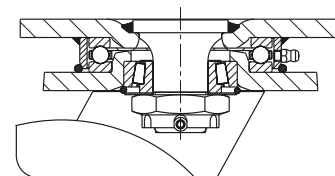

5

Swivel castors	Fixed castors	Swivel castor with "stop-top" brake	Wheel Ø [mm]	Wheel width [mm]	Load capacity [kg]	Bearing type	Total height [mm]	Plate size [mm]	Bolt hole spacing [mm]	Bolt hole Ø [mm]	Offset swivel castor [mm]
LS-GST 127K	BS-GST 127K	LS-GST 127K-ST	125	50	450	ball bearing	170	140 x 110	105 x 75–80	11	50
LS-GST 150K	BS-GST 150K	LS-GST 150K-ST	150	50	570	ball bearing	200	140 x 110	105 x 75–80	11	55
LS-GST 160K	BS-GST 160K	LS-GST 160K-ST	160	50	600	ball bearing	205	140 x 110	105 x 75–80	11	55
LS-GST 200K	BS-GST 200K	LS-GST 200K-ST	200	50	800	ball bearing	245	140 x 110	105 x 75–80	11	60
LS-GST 202K	BS-GST 202K	LS-GST 202K-ST	200	80	1,200	ball bearing	255	175 x 140	140 x 105	14	65
LS-GST 250K	BS-GST 250K	LS-GST 250K-ST	250	60	1,200	ball bearing	305	175 x 140	140 x 105	14	75
LS-GST 252K	BS-GST 252K	LS-GST 252K-ST	250	80	1,400	ball bearing	305	175 x 140	140 x 105	14	75
LS-GST 302K	BS-GST 302K	LS-GST 302K-ST	300	80	1,800	ball bearing	355	175 x 140	140 x 105	14	85
LS-GST 304K	BS-GST 304K		300	100	2,250	ball bearing	370	200 x 160	160 x 120	14	85

Versions / options



	antistatic version, non-marking grey	with directional lock 4 x 90°	with steel foot guard	truck lock
Technical description page	50	115	116	114
Product code suffix	-AS	-RI4	-FS	FF 125 / 150 / 160 / 200
Available for	upon request	wheel Ø 125–300x80 mm	wheel Ø 125–250 mm	wheel Ø 125–200x50 mm

LSD-GST, BSD-GST series

Welded steel heavy-duty twin wheel castors, heavy-duty swivel head, wheels with Blickle Softhane® polyurethane tread

900–6,000 kg

Bracket: LSD/BSD series

- particularly robust welded steel construction, zinc-plated, yellow-passivated, Cr6-free

Swivel bracket:

- axial grooved ball bearing ISO 104 and tapered roller bearing ISO 355 in the swivel head
- bolted and secured welded central kingpin, extremely strong
- dust and splash-proof
- grease nipple

Wheel: GST series

- tread: high-quality polyurethane elastomer Blickle Softhane®, hardness 75 Shore A, colour green, non-marking, non-staining
- wheel centre: rugged grey cast iron, with grease nipple from wheel Ø 160 mm, lacquered, colour silver

Additional details:

- bracket series: page 94
- brakes: page 112–113
- wheel series: page 301
- bearing types: page 84–85



5

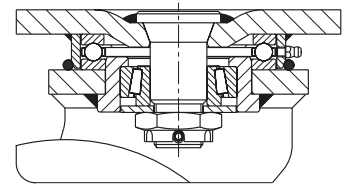

Swivel castors	Fixed castors	Wheel Ø [mm]	Wheel width [mm]	Load capacity [kg]	Bearing type	Total height [mm]	Plate size [mm]	Bolt hole spacing [mm]	Bolt hole Ø [mm]	Offset swivel castor [mm]
LSD-GST 127K	BSD-GST 127K	125	2 x 50	900	ball bearing	185	175 x 140	140 x 105	14	50
LSD-GST 150K-35	BSD-GST 150K-35	150	2 x 50	1,100	ball bearing	215	175 x 140	140 x 105	14	55
LSD-GST 200K-35	BSD-GST 200K-35	200	2 x 50	1,600	ball bearing	260	175 x 140	140 x 105	14	60
LSD-GST 202K	BSD-GST 202K	200	2 x 80	2,400	ball bearing	280	255 x 200	210 x 160	18	60
LSD-GST 250K	BSD-GST 250K	250	2 x 60	2,400	ball bearing	330	255 x 200	210 x 160	18	70
LSD-GST 252K	BSD-GST 252K	250	2 x 80	2,800	ball bearing	330	255 x 200	210 x 160	18	70
LSD-GST 304K	BSD-GST 304K	300	2 x 100	4,500	ball bearing	390	255 x 200	210 x 160	18	80
	BSD-GST 304K	300	2 x 100	4,500	ball bearing	390	300 x 200	210 x 160	18	–
LSD-GST 302K	BSD-GST 302K	300	2 x 80	3,600	ball bearing	390	255 x 200	210 x 160	18	80
LSD-GST 404K-42	BSD-GST 404K-42	400	2 x 100	6,000	ball bearing	530	400 x 300	340 x 240	26	125

Fixed castors: long side of plate parallel to the wheel axle

Versions / options



	antistatic version, non-marking grey	with "Radstop" wheel brake	with "Radstop" wheel brake	with directional lock 4 x 90°	with directional lock 4 x 90° (inserted by hand)	with steel foot guard
Technical description page	50	113	113	115	115	116
Product code suffix	-AS	-RA	-RAH	-RI4	-RI4H	-FS
Available for	upon request	up to wheel Ø 200x50 mm upon request	from wheel Ø 200x80 mm upon request	wheel Ø 125–200x50 mm upon request	wheel Ø 200x80–300 mm upon request	upon request

ALB series

Heavy-duty wheels
with **Blickle Besthane®** polyurethane tread,
with aluminium wheel centre

400–1,250 kg

Tread and tyre hardness

92 Shore A

Smooth operation / floor preservation

good

Rolling resistance

excellent

Wear resistance

excellent



Tread:

- high-quality polyurethane elastomer Blickle Besthane®, hardness 92 Shore A
- very low rolling resistance
- **high dynamic load capacity**
- high abrasion resistance
- high cut and tear propagation resistance
- colour brown, non-marking, non-staining
- excellent chemical connection with the wheel centre

Wheel centre:

- die-cast aluminium

Other features:

- high chemical resistance to many aggressive substances
- operating temperature: -20 °C to +70 °C, temporarily up to +90 °C, reduced load capacity over +40 °C

Additional details:

- wheel series: page 67
- tread: page 56
- bearing types: page 84–85
- chemical resistance: page 51

Wheels	Wheel Ø (D) [mm]	Wheel width (T2) [mm]	Load capacity at 4 km/h [kg]	Load capacity at 10 km/h [kg]	Load capacity at 16 km/h [kg]	Bearing type	Axle bore Ø (d) [mm]	Hub length (T1) [mm]
ALB 101/15K *	100	40	400	–	–	ball bearing	15	40
ALB 125/15K	125	40	550	–	–	ball bearing	15	45
ALB 150/20K	150	50	650	320	240	ball bearing	20	60
ALB 152/20K *	150	54	900	450	310	ball bearing	20	60
ALB 160/20K	160	50	750	370	280	ball bearing	20	60
ALB 162/20K *	160	50	950	470	330	ball bearing	20	60
ALB 181/20K	180	44	650	320	240	ball bearing	20	44
ALB 200/20K	200	50	800	400	300	ball bearing	20	60
ALB 202/20K *	200	50	1,000	500	350	ball bearing	20	60
ALB 250/25K	250	60	1,000	500	350	ball bearing	25	70
ALB 252/25K *	250	60	1,250	620	430	ball bearing	25	70

* With heavy-duty wheel centre, reinforced design

5

Versions / options

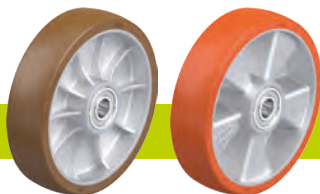

version with heavy duty wheel centre, reinforced design

other shore hardnesses and special colours

Technical description page

Product code suffix

Available for

upon request

ball bearing reinforced design

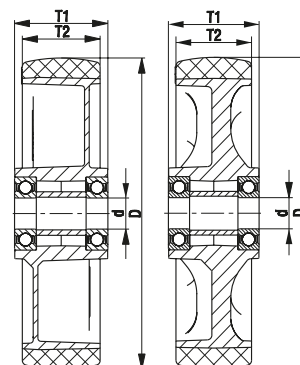

L-ALB, B-ALB, BH-ALB series

Pressed steel castors, medium-duty version, with top plate, wheel with Blickle Besthane® polyurethane tread



250–500 kg

Bracket: L/B/BH series

- pressed steel, zinc-plated, blue-passivated, Cr6-free

Swivel bracket:

- double ball bearing in the swivel head
- strong central kingpin (from wheel Ø 150 mm)
- swivel head seal
- minimum swivel head play and smooth rolling characteristic and increased service life due to the special dynamic Blickle riveting process

Wheel: ALB series

- tread: high-quality polyurethane elastomer Blickle Besthane®, hardness 92 Shore A, colour brown, non-marking, non-staining
- wheel centre: die-cast aluminium, colour silver grey

Additional details:

- bracket series: page 91
- brakes: page 112–113
- wheel series: page 307
- bearing types: page 84–85



5

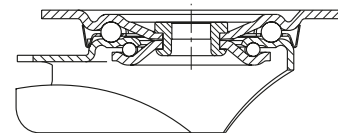

Swivel castors	Fixed castors	Swivel castors with "stop-fix" brake	Wheel Ø [mm]	Wheel width [mm]	Load capacity [kg]	Bearing type	Total height [mm]	Plate size [mm]	Bolt hole spacing [mm]	Bolt hole Ø [mm]	Offset swivel castor [mm]
L-ALB 101K	B-ALB 101K	L-ALB 101K-FI	100	40	250	ball bearing	125	100 x 85	80 x 60	9	35
L-ALB 125K	B-ALB 125K	L-ALB 125K-FI	125	40	250	ball bearing	150	100 x 85	80 x 60	9	38
L-ALB 150K	B-ALB 150K	L-ALB 150K-FI	150	50	400	ball bearing	190	140 x 110	105 x 75–80	11	60
L-ALB 160K	B-ALB 160K	L-ALB 160K-FI	160	50	400	ball bearing	195	140 x 110	105 x 75–80	11	60
L-ALB 200K	B-ALB 200K	L-ALB 200K-FI	200	50	400	ball bearing	235	140 x 110	105 x 75–80	11	65
L-ALB 250K-3	BH-ALB 250K	*	250	60	500	ball bearing	295	140 x 110	105 x 75–80	11	77

* "stop-top" brake version, see versions / options

Versions / options



	with "stop-top" brake	with "central-stop" central brake system	directional lock (separate) 1 x 360°	directional lock (separate) 1 x 360°	with steel foot guard
Technical description page	112	113	115	115	116
Product code suffix	-ST	-CS11	RI-03.01	RI-05.03	-FS
Available for	all	wheel Ø 160–200 mm	wheel Ø 100–125 mm**	wheel Ø 150–200 mm**	all

** Only for swivel castors without brake or swivel castor with "stop-top" and "central-stop" brake upon request

LK-ALB, BK-ALB, BH-ALB series

Pressed steel castors, heavy-duty design, with top plate, wheel with Blickle Besthane® polyurethane tread



350–600 kg

Bracket: LK/BK/BH series

- strong pressed steel, zinc-plated, blue-passivated, Cr6-free

Swivel bracket:

- double ball bearing in the swivel head
- strong central kingpin (from wheel Ø 125x50 mm)
- swivel head seal
- minimum swivel head play and smooth rolling characteristic and increased service life due to the special dynamic Blickle riveting process

Wheel: ALB series

- tread: high-quality polyurethane elastomer Blickle Besthane®, hardness 92 Shore A, colour brown, non-marking, non-staining
- wheel centre: die-cast aluminium, colour silver grey

Additional details:

- bracket series: page 92
- brakes: page 112–113
- wheel series: page 307
- bearing types: page 84–85

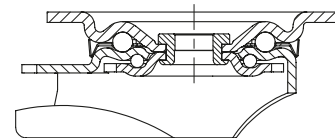

5

Swivel castors	Fixed castors	Swivel castors with "stop-fix" brake	Wheel Ø [mm]	Wheel width [mm]	Load capacity [kg]	Bearing type	Total height [mm]	Plate size [mm]	Bolt hole spacing [mm]	Bolt hole Ø [mm]	Offset swivel castor [mm]
LK-ALB 101K-1	BK-ALB 101K-1	LK-ALB 101K-1-FI	100	40	350	ball bearing	130	100 x 85	80 x 60	9	45
LK-ALB 101K-3	BK-ALB 101K-3	LK-ALB 101K-3-FI	100	40	350	ball bearing	130	140 x 110	105 x 75–80	11	45
LK-ALB 125K-1	BK-ALB 125K-1	LK-ALB 125K-1-FI	125	40	350	ball bearing	155	100 x 85	80 x 60	9	48
LK-ALB 125K-3	BK-ALB 125K-3	LK-ALB 125K-3-FI	125	40	350	ball bearing	155	140 x 110	105 x 75–80	11	48
LK-ALB 150K	BH-ALB 150K	LK-ALB 150K-FI	150	50	600	ball bearing	197	140 x 110	105 x 75–80	11	60
LK-ALB 160K	BH-ALB 160K	LK-ALB 160K-FI	160	50	600	ball bearing	202	140 x 110	105 x 75–80	11	60
LK-ALB 200K	BH-ALB 200K	LK-ALB 200K-FI	200	50	600	ball bearing	245	140 x 110	105 x 75–80	11	62

Versions / options



	with "stop-top" brake	with "ideal-stop" brake total height +17 mm	with directional lock (separate) 1x 360°	with steel foot guard
Technical description page	112	112	115	116
Product code suffix	-ST	-IS	see **	-FS
Available for	all	wheel Ø 160+200 mm*	for wheel Ø and plate dimensions, see**	upon request

* Synthetic adapter plate to balance out total height for swivel and fixed castors without "ideal-stop" brake: **product code AP3-17**

** **RI-05.01** for wheel Ø 100–125 mm with plate 100x85 mm, **RI-03.03** for wheel Ø 100–125 mm with plate 140x110 mm, **RI-05.03** for wheel Ø 150–200 mm (Only for swivel castors without brake or swivel castor with "stop-top" brake upon request)

LH-ALB, BH-ALB series

Pressed steel castors, heavy-duty design, with top plate, wheel with Blickle Besthane® polyurethane tread

400–900 kg

Bracket: LH/BH series

- strong pressed steel, zinc-plated, blue-passivated, Cr6-free
- heavy fork and top plate

Swivel bracket:

- double ball bearing in the swivel head
- bolted and secured central kingpin, extremely strong
- particularly resistant to shocks and impact due to **four specially-shaped, hardened bearing seats**

Wheel: ALB series

- tread: high-quality polyurethane elastomer Blickle Besthane®, hardness 92 Shore A, colour brown, non-marking, non-staining
- wheel centre: die-cast aluminium, colour silver grey

Additional details:

- bracket series: page 92
- brakes: page 112–113
- wheel series: page 307
- bearing types: page 84–85



5

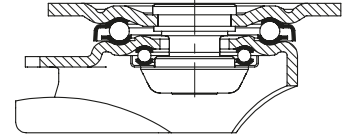

Swivel castors	Fixed castors	Swivel castors with "stop-fix" brake	Wheel Ø [mm]	Wheel width [mm]	Load capacity [kg]	Bearing type	Total height [mm]	Plate size [mm]	Bolt hole spacing [mm]	Bolt hole Ø [mm]	Offset swivel castor [mm]
LH-ALB 101K-1 *	BH-ALB 101K-1 *	LH-ALB 101K-1-FI *	100	40	400	ball bearing	140	100 x 85	80 x 60	9	45
LH-ALB 101K-3 *	BH-ALB 101K-3 *	LH-ALB 101K-3-FI *	100	40	400	ball bearing	140	140 x 110	105 x 75–80	11	45
LH-ALB 125K-1	BH-ALB 125K-1	LH-ALB 125K-1-FI	125	40	550	ball bearing	165	100 x 85	80 x 60	9	45
LH-ALB 125K-3	BH-ALB 125K-3	LH-ALB 125K-3-FI	125	40	550	ball bearing	165	140 x 110	105 x 75–80	11	45
LH-ALB 150K	BH-ALB 150K	LH-ALB 150K-FI	150	50	650	ball bearing	197	140 x 110	105 x 75–80	11	65
LH-ALB 152K *	BH-ALB 152K *	LH-ALB 152K-FI *	150	54	900	ball bearing	197	140 x 110	105 x 75–80	11	65
LH-ALB 160K	BH-ALB 160K	LH-ALB 160K-FI	160	50	750	ball bearing	202	140 x 110	105 x 75–80	11	65
LH-ALB 162K *	BH-ALB 162K *	LH-ALB 162K-FI *	160	50	900	ball bearing	202	140 x 110	105 x 75–80	11	65
LH-ALB 200K	BH-ALB 200K	LH-ALB 200K-FI	200	50	800	ball bearing	245	140 x 110	105 x 75–80	11	70
LH-ALB 202K *	BH-ALB 202K *	LH-ALB 202K-FI *	200	50	900	ball bearing	245	140 x 110	105 x 75–80	11	70
LH-ALB 250K	BH-ALB 250K	**	250	60	900	ball bearing	295	140 x 110	105 x 75–80	11	82
LH-ALB 252K *	BH-ALB 252K *	**	250	60	900	ball bearing	295	140 x 110	105 x 75–80	11	82

* Heavy-duty wheel version

** "stop-top" brake version, see versions / options

Versions / options



	version with heavy duty wheel centre, reinforced design	with "stop-top" brake	with "central-stop" central brake system	with "ideal-stop" brake total height +17 mm	with directional lock (separate) 1x 360°	with steel foot guard	truck lock
Technical description page		112	113	112	115	116	114
Product code suffix		-ST	-CS13	-IS	see ****	-FS	FF 125 / 150 / 160 / 200
Available for		all	wheel Ø 160–200 mm	wheel Ø 160–200 mm****	for wheel Ø and plate dimensions, see****	all	wheel Ø 125, 150, 160, 200 mm

*** Synthetic adapter plate to balance out total height for swivel and fixed castors without "ideal-stop" brake: **product code AP3-17**

**** **RI-04.01** for wheel Ø 100–125 mm with plate 100x85 mm, **RI-04.03** for wheel Ø 100–125x40 mm with plate 140x110 mm, **RI-05.03** for wheel Ø 125x54–200 mm (Only for swivel castors without brake or swivel castor with "stop-top" and "central-stop" brake upon request)

LHD-ALB, BOD-ALB series

Pressed steel twin wheel castors, heavy-duty design, with top plate, wheels with Blickle Besthane® polyurethane tread



720–900 kg

Bracket: LHD/BOD series

- strong pressed steel, zinc-plated, blue-passivated, Cr6-free (fixed bracket: solid welded steel construction)
- heavy fork and top plate

Swivel bracket:

- double ball bearing in the swivel head
- bolted and secured central kingpin, extremely strong
- particularly resistant to shocks and impact due to **four specially-shaped, hardened bearing seats**

Wheel: ALB series

- tread: high-quality polyurethane elastomer Blickle Besthane®, hardness 92 Shore A, colour brown, non-marking, non-staining
- wheel centre: die-cast aluminium, colour silver grey

Additional details:

- bracket series: page 93
- wheel series: page 307
- bearing types: page 84–85

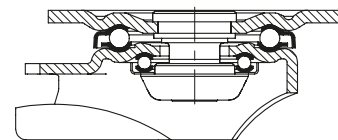

Swivel castors	Fixed castors	Wheel Ø [mm]	Wheel width [mm]	Load capacity [kg]	Bearing type	Total height [mm]	Plate size [mm]	Bolt hole spacing [mm]	Bolt hole Ø [mm]	Offset swivel castor [mm]
LHD-ALB 101K *	BOD-ALB 101K *	100	2 x 40	720	ball bearing	145	140 x 110	105 x 75–80	11	45
LHD-ALB 125K	BOD-ALB 125K	125	2 x 40	900	ball bearing	170	140 x 110	105 x 75–80	11	50
LHD-ALB 181K	BOD-ALB 181K	180	2 x 44	800	ball bearing	235	140 x 110	105 x 75–80	11	65

* Heavy-duty wheel version

Fixed castors: long side of plate parallel to the wheel axle

Versions / options



truck lock

Technical description page

114

Product code suffix

FF 100-1 / FF 125-1

Available for

wheel Ø 100+125 mm

VSB, GB series, wheel Ø 80–200 mm

Heavy-duty wheels
with **Blickle Besthane® polyurethane tread**,
with **steel or cast iron wheel centre**

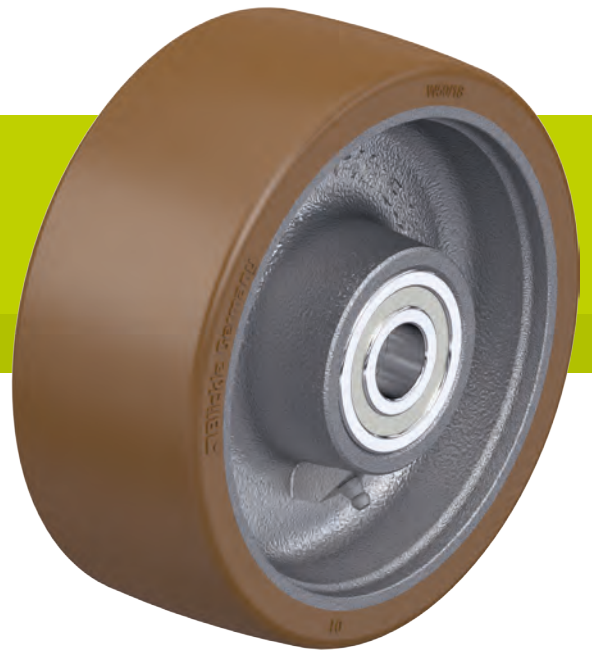

450–1,600 kg

Tread and tyre hardness
 92 Shore A

Smooth operation / floor preservation
 good

Rolling resistance
 excellent

Wear resistance
 excellent



Tread:

- high-quality polyurethane elastomer Blickle Besthane®, hardness 92 Shore A
- very low rolling resistance
- **high dynamic load capacity**
- high abrasion resistance
- high cut and tear propagation resistance
- colour brown, non-marking, non-staining
- excellent chemical connection with the wheel centre

Wheel centre:

- series VSB: steel
- series GB: rugged grey cast iron, with grease nipple from wheel Ø 150 mm, lacquered, colour silver

Other features:

- high chemical resistance to many aggressive substances
- operating temperature: -20 °C to +70 °C, temporarily up to +90 °C, reduced load capacity over +40 °C

Additional details:

- wheel series: page 67
- tread: page 56
- bearing types: page 84–85
- chemical resistance: page 51

Wheels	Wheel Ø (D) [mm]	Wheel width (T2) [mm]	Load capacity at 4 km/h [kg]	Load capacity at 10 km/h [kg]	Load capacity at 16 km/h [kg]	Bearing type	Axle bore Ø (d) [mm]	Hub length (T1) [mm]
VSB 82/20K	80	70	500	–	–	ball bearing	20	70
GB 100/15K	100	40	450	–	–	ball bearing	15	40
GB 101/20-50K	100	50	600	–	–	ball bearing	20	50
GB 101/20K	100	50	600	–	–	ball bearing	20	60
GB 125/15K	125	40	550	–	–	ball bearing	15	45
GB 128/20K	125	60	850	590	340	ball bearing	20	60
GB 140/20K	140	54	900	630	360	ball bearing	20	60
GB 150/20-50K	150	50	800	560	320	ball bearing	20	50
GB 150/20K	150	50	800	560	320	ball bearing	20	60
GB 152/20K	150	60	950	660	380	ball bearing	20	60
GB 152/25K	150	60	950	660	380	ball bearing	25	60
GB 154/25K	150	80	1,200	840	480	ball bearing	25	80
GB 160/20K	160	50	800	560	320	ball bearing	20	60
GB 160/25K	160	50	800	560	320	ball bearing	25	60
GB 180/20K	180	50	1,000	700	400	ball bearing	20	60
GB 180/25K	180	50	1,000	700	400	ball bearing	25	60
GB 182/25K	180	65	1,100	770	440	ball bearing	25	75
GB 184/25K	180	80	1,400	980	560	ball bearing	25	80
GB 200/20K	200	50	1,000	700	400	ball bearing	20	60
GB 200/25K	200	50	1,000	700	400	ball bearing	25	60
GB 201/25K	200	60	1,400	980	560	ball bearing	25	60
GB 202/25K	200	80	1,600	1,100	640	ball bearing	25	90
GB 202/30K	200	80	1,600	1,100	640	ball bearing	30	90
GB 202/35K	200	80	1,600	1,100	640	ball bearing	35	90

Greatly increased load capacity is possible for applications without obstacles.

For other wheel Ø, see next page

Versions / options



	hydrolysis resistant, with cast nylon wheel centre	drive wheels with hub keyway	hub fitting wheels	electrically conductive version, non-marking	other shore hardnesses and special colours
Technical description page	56	76	78	50	
Product code suffix	GSPOB series	GBN series	GBA series	-ELS	
Available for	upon request	see page 544–545	see page 552	upon request	upon request

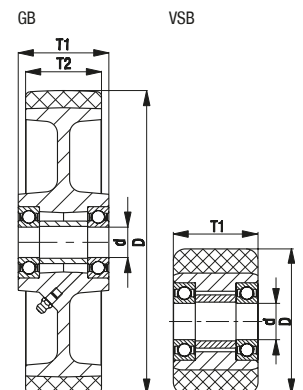

GB series, wheel Ø 250–1,000 mm

Heavy-duty wheels
with **Blickle Besthane® polyurethane tread**,
with **cast iron wheel centre**



1,250–30,000 kg

Tread and tyre hardness

92 Shore A

Smooth operation / floor preservation

good

Rolling resistance

excellent

Wear resistance

excellent



Tread:

- high-quality polyurethane elastomer Blickle Besthane®, hardness 92 Shore A
- very low rolling resistance
- **high dynamic load capacity**
- high abrasion resistance
- high cut and tear propagation resistance
- colour brown, non-marking, non-staining
- excellent chemical connection with the wheel centre

Wheel centre:

- rugged grey cast iron
- with grease nipple
- lacquered, colour silver

Other features:

- high chemical resistance to many aggressive substances
- operating temperature: -20 °C to +70 °C, temporarily up to +90 °C, reduced load capacity over +40 °C

Additional details:

- wheel series: page 67
- tread: page 56
- bearing types: page 84–85
- chemical resistance: page 51

Wheels	Wheel Ø (D) [mm]	Wheel width (T2) [mm]	Load capacity at 4 km/h [kg]	Load capacity at 10 km/h [kg]	Load capacity at 16 km/h [kg]	Bearing type	Axle bore Ø (d) [mm]	Hub length (T1) [mm]
GB 251/25K	250	50	1,250	870	500	ball bearing	25	60
GB 251/30K	250	50	1,250	870	500	ball bearing	30	60
GB 250/25K	250	60	1,500	1,050	600	ball bearing	25	70
GB 250/30K	250	60	1,500	1,050	600	ball bearing	30	70
GB 250/30K-01	250	60	1,750	1,200	700	ball bearing	30	70
GB 250/35K	250	60	1,500	1,050	600	ball bearing	35	70
GB 252/25K	250	80	1,800	1,250	720	ball bearing	25	90
GB 252/30K	250	80	2,200	1,550	880	ball bearing	30	90
GB 253/35K	250	100	2,650	1,850	1,050	ball bearing	35	100
GB 254/40K	250	130	3,150	2,200	1,250	ball bearing	40	140
GB 300/30K	300	60	1,800	1,250	720	ball bearing	30	70
GB 302/30K	300	80	2,400	1,650	960	ball bearing	30	90
GB 302/35K	300	80	2,400	1,650	960	ball bearing	35	90
GB 304/35K	300	100	3,000	2,100	1,200	ball bearing	35	120
GB 306/50K	300	140	3,700	2,600	1,500	ball bearing	50	140
GB 360/40K	360	75	2,500	1,750	1,000	ball bearing	40	90
GB 362/40K	360	80	3,000	2,100	1,200	ball bearing	40	90
GB 363/40K	360	100	3,600	2,500	1,450	ball bearing	40	100
GB 364/40K	360	120	3,800	2,650	1,500	ball bearing	40	120
GB 402/40K	400	80	3,000	2,100	1,200	ball bearing	40	90
GB 404/40K	400	100	3,800	2,650	1,500	ball bearing	40	120
GB 406/50K	400	125	5,000	3,500	2,000	ball bearing	50	125
GB 408/50K	400	150	5,700	4,000	2,250	ball bearing	50	150
GB 500/50K	500	100	5,000	3,500	2,000	ball bearing	50	100
GB 504/60K	500	150	7,500	5,250	3,000	ball bearing	60	150
GB 506/80K	500	200	10,000	7,000	4,000	ball bearing	80	200
GB 602/80K	600	150	9,000	6,300	3,600	ball bearing	80	150
GB 604/80K	600	200	12,000	8,400	4,800	ball bearing	80	200
GB 750/120K	750	200	15,000	10,500	6,000	ball bearing	120	200
GB 1000/160PR	1,000	300	30,000	21,000	12,000	spherical roller bearing	160	330

Greatly increased load capacity is possible for applications without obstacles.

Other dimensions available upon request

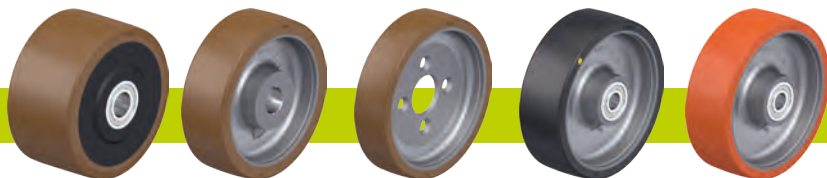

Versions / options

	hydrolysis resistant, with cast nylon wheel centre	drive wheels with hub keyway	hub fitting wheels	electrically conductive version, non-marking	other shore hardnesses and special colours
Technical description page	56	76	78	50	
Product code suffix	GSPOB series	GBN series	GBA series	-ELS	
Available for	upon request	see page 544–545	see page 552	up to wheel Ø 300 mm upon request	upon request

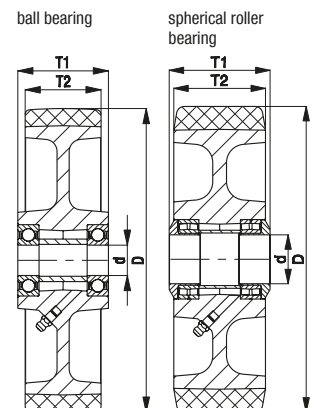

LH-VSB, LH-GB, BH-GB series

Pressed steel castors, heavy-duty design, with top plate, wheel with Blickle Besthane® polyurethane tread

450–900 kg



Bracket: LH/BH series

- strong pressed steel, zinc-plated, blue-passivated, Cr6-free
- heavy fork and top plate

Swivel bracket:

- double ball bearing in the swivel head
- bolted and secured central kingpin, extremely strong
- particularly resistant to shocks and impact due to **four specially-shaped, hardened bearing seats**

Wheel: VSB/GB series

- tread: high-quality polyurethane elastomer Blickle Besthane®, hardness 92 Shore A, colour brown, non-marking, non-staining

wheel centre:

- VSB series: steel
- GB series: rugged grey cast iron, with grease nipple from wheel Ø 150 mm, lacquered, colour silver

Additional details:

- bracket series: page 92
- brakes: page 112–113
- wheel series: page 312–313
- bearing types: page 84–85



5

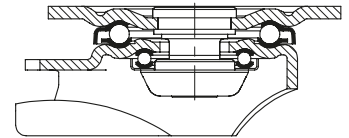

Swivel castors	Fixed castors	Swivel castors with "stop-fix" brake	Wheel Ø [mm]	Wheel width [mm]	Load capacity [kg]	Bearing type	Total height [mm]	Plate size [mm]	Bolt hole spacing [mm]	Bolt hole Ø [mm]	Offset swivel castor [mm]
LH-VSB 82K			80	70	500	ball bearing	112	100 x 85	80 x 60	9	45
LH-GB 100K-1	BH-GB 100K-1	LH-GB 100K-1-FI	100	40	450	ball bearing	140	100 x 85	80 x 60	9	45
LH-GB 100K-3	BH-GB 100K-3	LH-GB 100K-3-FI	100	40	450	ball bearing	140	140 x 110	105 x 75–80	11	45
LH-GB 125K-1	BH-GB 125K-1	LH-GB 125K-1-FI	125	40	550	ball bearing	165	100 x 85	80 x 60	9	45
LH-GB 125K-3	BH-GB 125K-3	LH-GB 125K-3-FI	125	40	550	ball bearing	165	140 x 110	105 x 75–80	11	45
LH-GB 128K	BH-GB 128K	LH-GB 128K-FI	125	60	850	ball bearing	170	140 x 110	105 x 75–80	11	55
LH-GB 150K	BH-GB 150K	LH-GB 150K-FI	150	50	800	ball bearing	197	140 x 110	105 x 75–80	11	65
LH-GB 160K	BH-GB 160K	LH-GB 160K-FI	160	50	800	ball bearing	202	140 x 110	105 x 75–80	11	65
LH-GB 180K	BH-GB 180K	LH-GB 180K-FI	180	50	900	ball bearing	223	140 x 110	105 x 75–80	11	65
LH-GB 200K	BH-GB 200K	LH-GB 200K-FI	200	50	900	ball bearing	245	140 x 110	105 x 75–80	11	70
LH-GB 202K	BO-GB 202K *	**	200	80	800	ball bearing	245	140 x 110	105 x 75–80	11	70
LH-GB 250K	BH-GB 250K	**	250	60	900	ball bearing	295	140 x 110	105 x 75–80	11	82

* Welded steel construction

** "stop-top" brake version, see versions / options

Versions / options***



	hydrolysis resistant, with cast nylon wheel centre	electrically conductive version, non-marking	with "stop-top" brake	with "central-stop" central brake system	with "ideal-stop" brake total height +17 mm	with directional lock (separate) 1x 360°	truck lock
Technical description page	56	50	112	113	112	115	114
Product code suffix	GSPOB series	-ELS	-ST	-CS13	-IS	see *****	FF 125 / 150 / 160 / 200
Available for	upon request	upon request	wheel Ø 100–250 mm	wheel Ø 160+200x50 mm	wheel Ø 160+200 mm****	for wheel Ø and plate dimensions, see*****	wheel Ø 125x60, 150, 160, 200 mm

*** Additional versions / options: with steel foot guard (-FS), available for wheel Ø 100–250 mm

**** Synthetic adapter plate to balance out total height for swivel and fixed castors without "ideal-stop" brake: product code AP3-17

***** RI-04.01 for wheel Ø 100–125 mm with plate 100x85 mm, RI-04.03 for wheel Ø 100–125x40 mm with plate 140x110 mm, RI-05.03 for wheel Ø 125x60–200x50 mm (Only for swivel castors without brake or swivel castor with "stop-top" and "central-stop" brake upon request)

LUH-GB, BH-GB series

Pressed steel castors, heavy-duty design, enclosed, with top plate, wheel with Blickle Besthane® polyurethane tread

800–1,000 kg



Bracket: LUH/BH series

- strong pressed steel, zinc-plated, blue-passivated, Cr6-free

Swivel bracket:

- four-point ball bearing for extremely heavy loads
- enclosed and sealed swivel head
- particularly resistant to shocks and impact due to **specialty-shaped, hardened bearing seats**

Wheel: GB series

- tread: high-quality polyurethane elastomer Blickle Besthane®, hardness 92 Shore A, colour brown, non-marking, non-staining
- wheel centre: rugged grey cast iron, with grease nipple from wheel Ø 150 mm, lacquered, colour silver

Additional details:

- bracket series: page 93
- brakes: page 112–113
- wheel series: page 312
- bearing types: page 84–85

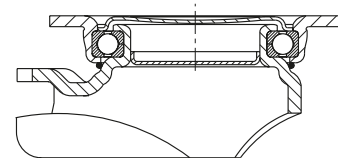

5

Swivel castors	Fixed castors	Swivel castors with "stop-fix" brake	Wheel Ø [mm]	Wheel width [mm]	Load capacity [kg]	Bearing type	Total height [mm]	Plate size [mm]	Bolt hole spacing [mm]	Bolt hole Ø [mm]	Offset swivel castor [mm]
LUH-GB 128K	BH-GB 128K	LUH-GB 128K-FI	125	60	850	ball bearing	170	140 x 110	105 x 75–80	11	55
LUH-GB 150K	BH-GB 150K	LUH-GB 150K-FI	150	50	800	ball bearing	197	140 x 110	105 x 75–80	11	61
LUH-GB 160K	BH-GB 160K	LUH-GB 160K-FI	160	50	800	ball bearing	202	140 x 110	105 x 75–80	11	61
LUH-GB 200K	BH-GB 200K	LUH-GB 200K-FI	200	50	1,000	ball bearing	245	140 x 110	105 x 75–80	11	63

Versions / options



	hydrolysis resistant, with cast nylon wheel centre	electrically conductive version, non-marking	directional lock (separate) 1 x 360°	with steel foot guard
Technical description page	56	50	115	116
Product code suffix	GSP0B series	-ELS	RI-05.03	-FS
Available for	upon request	upon request	all*	upon request

* Only for swivel castors without brake

LS-GB, BS-GB series

Welded steel heavy-duty castors, heavy-duty swivel head, wheel with Blickle Besthane® polyurethane tread

800–12,000 kg

Bracket: LS/BS series

- particularly robust welded steel construction, zinc-plated, yellow-passivated, Cr6-free
- Swivel bracket:
 - axial grooved ball bearing ISO 104 and tapered roller bearing ISO 355 in the swivel head
 - bolted and secured welded central kingpin, extremely strong
 - dust and splash-proof
 - grease nipple

Wheel: GB series

- tread: high-quality polyurethane elastomer Blickle Besthane®, hardness 92 Shore A, colour brown, non-marking, non-staining
- wheel centre: rugged grey cast iron, with grease nipple from wheel Ø 150 mm, lacquered, colour silver

Additional details:

- bracket series: page 94
- brakes: page 112–113
- wheel series: page 312–313
- bearing types: page 84–85



5

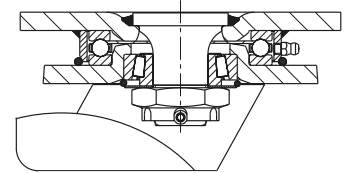

Swivel castors	Fixed castors	Swivel castor with "stop-top" brake	Wheel Ø [mm]	Wheel width [mm]	Load capacity [kg]	Bearing type	Total height [mm]	Plate size [mm]	Bolt hole spacing [mm]	Bolt hole Ø [mm]	Offset swivel castor [mm]
LS-GB 128K	BS-GB 128K	LS-GB 128K-ST	125	60	850	ball bearing	170	140 x 110	105 x 75–80	11	50
LS-GB 150K	BS-GB 150K	LS-GB 150K-ST	150	50	800	ball bearing	200	140 x 110	105 x 75–80	11	55
LS-GB 152K	BS-GB 152K	LS-GB 152K-ST	150	60	950	ball bearing	200	140 x 110	105 x 75–80	11	55
LS-GB 154K	BS-GB 154K	LS-GB 154K-ST	150	80	1,200	ball bearing	205	175 x 140	140 x 105	14	65
LS-GB 160K	BS-GB 160K	LS-GB 160K-ST	160	50	800	ball bearing	205	140 x 110	105 x 75–80	11	55
LS-GB 200K	BS-GB 200K	LS-GB 200K-ST	200	50	1,000	ball bearing	245	140 x 110	105 x 75–80	11	60
LS-GB 202K	BS-GB 202K	LS-GB 202K-ST	200	80	1,600	ball bearing	255	175 x 140	140 x 105	14	65
LS-GB 250K	BS-GB 250K	LS-GB 250K-ST	250	60	1,500	ball bearing	305	175 x 140	140 x 105	14	75
LS-GB 252K	BS-GB 252K	LS-GB 252K-ST	250	80	1,800	ball bearing	305	175 x 140	140 x 105	14	75
LS-GB 300K	BS-GB 300K	LS-GB 300K-ST	300	60	1,800	ball bearing	355	175 x 140	140 x 105	14	85
LS-GB 302K	BS-GB 302K	LS-GB 302K-ST	300	80	2,400	ball bearing	355	175 x 140	140 x 105	14	85
LS-GB 304K	BS-GB 304K	*	300	100	3,000	ball bearing	370	200 x 160	160 x 120	14	85
LS-GB 360K	BS-GB 360K	*	360	75	2,500	ball bearing	430	200 x 160	160 x 120	14	100
LS-GB 364K	BS-GB 364K	*	360	120	3,800	ball bearing	430	255 x 200	210 x 160	18	100
LS-GB 402K	BS-GB 402K	*	400	80	3,000	ball bearing	470	200 x 160	160 x 120	14	100
LS-GB 406K	BS-GB 406K	*	400	125	5,000	ball bearing	480	255 x 200	210 x 160	18	125
LS-GB 504K	BS-GB 504K	*	500	150	7,500	ball bearing	630	400 x 300	340 x 240	26	125
LS-GB 604K	BS-GB 604K	*	600	200	12,000	ball bearing	730	400 x 300	340 x 240	26	130

* "Radstop" brake version

Versions / options

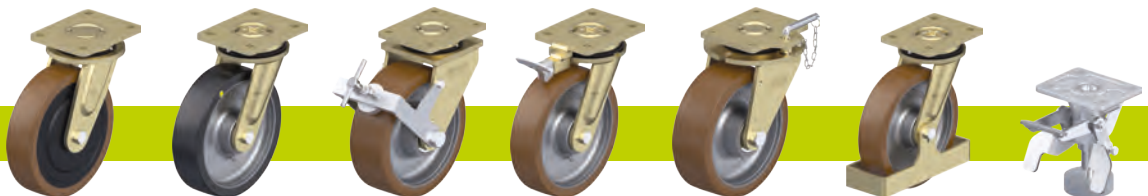

	hydrolysis resistant, with cast nylon wheel centre	electrically conductive version, non-marking	with "Radstop" wheel brake	with directional lock 4 x 90°	with directional lock 4 x 90° (inserted by hand)	with steel foot guard	truck lock
Technical description page	56	50	113	115	115	116	114
Product code suffix	GSPOB series	-ELS	-RAH	-RI4	-RI4H	-FS	FF 125 / 150 / 160 / 200
Available for	upon request	up to wheel Ø 300 mm upon request	from wheel Ø 300x100 mm upon request	wheel Ø 125–300x80 mm	from wheel Ø 300x100 mm upon request	wheel Ø 125–250 mm	wheel Ø 125–200x50 mm

LSD-GB, BSD-GB series

Welded steel heavy-duty twin wheel castors, heavy-duty swivel head, wheels with Blickle Besthane® polyurethane tread

810–12,000 kg

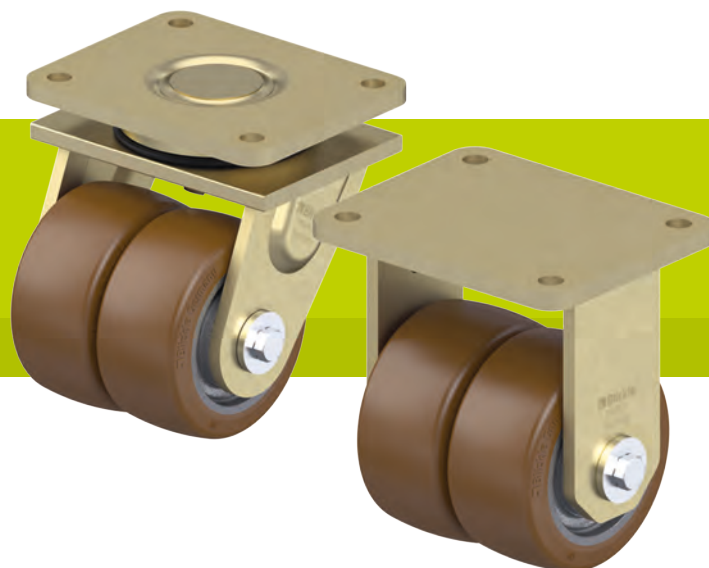

Bracket: LSD/BSD series

- particularly robust welded steel construction, zinc-plated, yellow-passivated, Cr6-free

Swivel bracket:

- axial grooved ball bearing ISO 104 and tapered roller bearing ISO 355 in the swivel head
- bolted and secured welded central kingpin, extremely strong
- dust and splash-proof
- grease nipple

Wheel: GB series

- tread: high-quality polyurethane elastomer Blickle Besthane®, hardness 92 Shore A, colour brown, non-marking, non-staining
- wheel centre: rugged grey cast iron, with grease nipple from wheel Ø 150 mm, lacquered, colour silver

Additional details:

- bracket series: page 94
- brakes: page 112–113
- wheel series: page 312–313
- bearing types: page 84–85

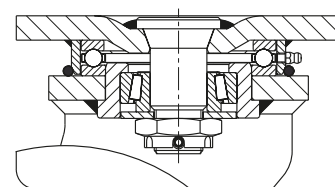

5

Swivel castors	Fixed castors	Wheel Ø [mm]	Wheel width [mm]	Load capacity [kg]	Bearing type	Total height [mm]	Plate size [mm]	Bolt hole spacing [mm]	Bolt hole Ø [mm]	Offset swivel castor [mm]
LSD-GB 100K	BSD-GB 100K	100	2 x 40	810	ball bearing	145	140 x 110	105 x 75–80	11	45
LSD-GB 128K	BSD-GB 128K	125	2 x 60	1,500	ball bearing	185	175 x 140	140 x 105	14	50
LSD-GB 150K-35	BSD-GB 150K-35	150	2 x 50	1,400	ball bearing	215	175 x 140	140 x 105	14	55
LSD-GB 200K-35	BSD-GB 200K-35	200	2 x 50	1,800	ball bearing	260	175 x 140	140 x 105	14	60
LSD-GB 202K	BSD-GB 202K	200	2 x 80	2,850	ball bearing	280	255 x 200	210 x 160	18	60
LSD-GB 250K	BSD-GB 250K	250	2 x 60	2,700	ball bearing	330	255 x 200	210 x 160	18	70
LSD-GB 252K	BSD-GB 252K	250	2 x 80	3,700	ball bearing	330	255 x 200	210 x 160	18	70
LSD-GB 302K	BSD-GB 302K	300	2 x 80	4,300	ball bearing	390	255 x 200	210 x 160	18	80
LSD-GB 304K		300	2 x 100	5,400	ball bearing	390	255 x 200	210 x 160	18	80
	BSD-GB 304K	300	2 x 100	5,400	ball bearing	390	300 x 200	210 x 160	18	–
LSD-GB 404K-42	BSD-GB 404K-42	400	2 x 100	6,800	ball bearing	530	400 x 300	340 x 240	26	125
LSD-GB 504K	BSD-GB 504K	500	2 x 150	12,000	ball bearing	630	400 x 300	340 x 240	26	125

Fixed castors: long side of plate parallel to the wheel axle

Versions / options



	hydrolysis resistant, with cast nylon wheel centre	electrically conductive version, non-marking	with "Radstop" wheel brake	with "Radstop" wheel brake	with directional lock 4 x 90°	with directional lock 4 x 90° (inserted by hand)	with steel foot guard
Technical description page	56	50	113	113	115	115	116
Product code suffix	GSP0B series	-ELS	-RA	-RAH	-RI4	-RI4H	-FS
Available for	upon request	up to wheel Ø 300 mm upon request	up to wheel Ø 200x50 mm upon request	from wheel Ø 200x80 mm upon request	wheel Ø 100–200x50 mm upon request	from wheel Ø 200x80 mm upon request	upon request

POBS series

Heavy-duty wheels with Blickle Besthane® Soft polyurethane tread, with nylon wheel centre

140–500 kg

Tread and tyre hardness

75 Shore A

Smooth operation / floor preservation

very good

Rolling resistance

excellent

Wear resistance

very good



Tread:

- high-quality polyurethane elastomer Blickle Besthane® Soft, hardness 75 Shore A
- extra-thick elastic tread for excellent operational comfort
- very good floor preservation, low-noise operation
- very low rolling resistance
- **high dynamic load capacity**
- high abrasion resistance
- high cut and tear propagation resistance
- colour blue, non-marking, non-staining
- excellent chemical connection with the wheel centre

Wheel centre:

- high-quality nylon 6, impact resistant
- colour black

Other features:

- XKA version: with synthetic thread guard, small
- XKF version: with synthetic thread guard, large
- corrosion and hydrolysis-resistant
- high chemical resistance to many aggressive substances
- operating temperature: -20 °C to +70 °C, temporarily up to +90 °C, reduced load capacity over +35 °C

Additional details:

- wheel series: page 68
- tread: page 56
- bearing types: page 84–85
- chemical resistance: page 51

Wheels	Wheel Ø (D) [mm]	Wheel width (T2) [mm]	Load capacity [kg]	Bearing type	Axle bore Ø (d) [mm]	Hub length (T1) [mm]
POBS 80/8XKF	80	30	140	ball bearing (C)	8	36
POBS 100/8XKA	100	38	200	ball bearing (C)	8	46
POBS 100/10XKA	100	38	200	ball bearing (C)	10	46
POBS 125/8XKA	125	40	250	ball bearing (C)	8	46
POBS 125/10XKA	125	40	250	ball bearing (C)	10	46
POBS 160/12XKA	160	50	400	ball bearing (CC)	12	60
POBS 200/12XKA	200	50	500	ball bearing (CC)	12	60

Versions / options



	other shore hardnesses and special colours	stainless steel castors with top plate fitting	stainless steel heavy duty castors with top plate fitting
Technical description page		415	416
Product code suffix		LEX-POBS series	LKX-POBS series
Available for	upon request	wheel Ø 80–200 mm	wheel Ø 100–200 mm

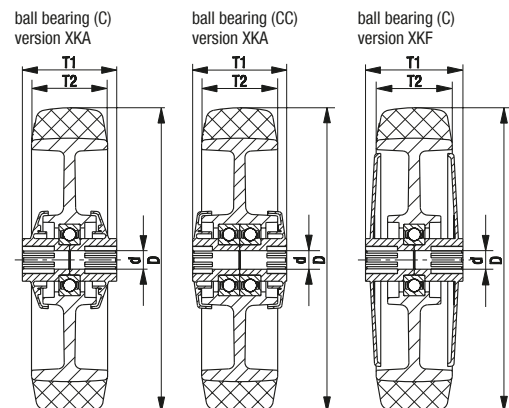

ALBS series

Heavy-duty wheels
with **Blickle Besthane® Soft polyurethane tread**,
with **aluminium wheel centre**



200–1,150 kg

Tread and tyre hardness

75 Shore A

Smooth operation / floor preservation

very good

Rolling resistance

excellent

Wear resistance

very good



Tread:

- high-quality polyurethane elastomer Blickle Besthane® Soft, hardness 75 Shore A
- extra-thick elastic tread for excellent operational comfort
- very good floor preservation, low-noise operation
- very low rolling resistance
- **high dynamic load capacity**
- high abrasion resistance
- high cut and tear propagation resistance
- colour blue, non-marking, non-staining
- excellent chemical connection with the wheel centre

Wheel centre:

- die-cast aluminium

Other features:

- high chemical resistance to many aggressive substances
- operating temperature: -20 °C to +70 °C, temporarily up to +90 °C, reduced load capacity over +40 °C

Additional details:

- wheel series: page 68
- tread: page 56
- bearing types: page 84–85
- chemical resistance: page 51

Wheels	Wheel Ø (D) [mm]	Wheel width (T2) [mm]	Load capacity at 4 km/h [kg]	Load capacity at 10 km/h [kg]	Load capacity at 16 km/h [kg]	Bearing type	Axle bore Ø (d) [mm]	Hub length (T1) [mm]
ALBS 80/15K	80	30	200	–	–	ball bearing	15	35
ALBS 82/15K	80	40	230	–	–	ball bearing	15	40
ALBS 100/15K	100	40	320	–	–	ball bearing	15	40
ALBS 125/15K	125	40	370	–	–	ball bearing	15	45
ALBS 127/20K	125	54	450	220	180	ball bearing	20	60
ALBS 150/20K	150	50	500	250	200	ball bearing	20	60
ALBS 160/20K	160	50	580	270	220	ball bearing	20	60
ALBS 181/20K	180	44	450	220	180	ball bearing	20	44
ALBS 180/20K	180	50	670	335	240	ball bearing	20	60
ALBS 200/20K	200	50	750	370	300	ball bearing	20	60
ALBS 250/20K	250	50	850	400	320	ball bearing	20	60
ALBS 250/25K	250	50	850	400	320	ball bearing	25	60
ALBS 300/25K	300	60	1,150	570	460	ball bearing	25	70

5

Versions / options



with extremely crowned tread

other shore hardnesses and special colours

Technical description page	55	
Product code suffix	-CO	
Available for	wheel Ø 125x40, 160, 200 mm, others upon request	upon request

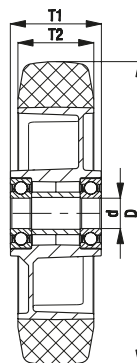

LK-ALBS, BK-ALBS, BH-ALBS series

Pressed steel castors, heavy-duty design, with top plate, wheel with Blickle Besthane® Soft polyurethane tread

230–600 kg

Bracket: LK/BK/BH series

- strong pressed steel, zinc-plated, blue-passivated, Cr6-free

Swivel bracket:

- double ball bearing in the swivel head
- strong central kingpin (from wheel Ø 125x50 mm)
- swivel head seal
- minimum swivel head play and smooth rolling characteristic and increased service life due to the special dynamic Blickle riveting process

Wheel: ALBS series

- tread: high-quality polyurethane elastomer Blickle Besthane® Soft, hardness 75 Shore A, colour blue, non-marking, non-staining
- wheel centre: die-cast aluminium, colour silver grey

Additional details:

- bracket series: page 92
- brakes: page 112–113
- wheel series: page 319
- bearing types: page 84–85



5

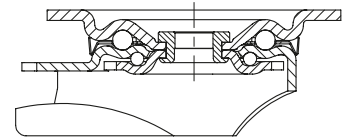

Swivel castors	Fixed castors	Swivel castors with "stop-fix" brake	Wheel Ø [mm]	Wheel width [mm]	Load capacity [kg]	Bearing type	Total height [mm]	Plate size [mm]	Bolt hole spacing [mm]	Bolt hole Ø [mm]	Offset swivel castor [mm]
LK-ALBS 82K	BK-ALBS 82K	LK-ALBS 82K-FI	80	40	230	ball bearing	110	100 x 85	80 x 60	9	40
LK-ALBS 100K-1	BK-ALBS 100K-1	LK-ALBS 100K-1-FI	100	40	320	ball bearing	130	100 x 85	80 x 60	9	45
LK-ALBS 100K-3	BK-ALBS 100K-3	LK-ALBS 100K-3-FI	100	40	320	ball bearing	130	140 x 110	105 x 75–80	11	45
LK-ALBS 125K-1	BK-ALBS 125K-1	LK-ALBS 125K-1-FI	125	40	350	ball bearing	155	100 x 85	80 x 60	9	48
LK-ALBS 125K-3	BK-ALBS 125K-3	LK-ALBS 125K-3-FI	125	40	350	ball bearing	155	140 x 110	105 x 75–80	11	48
LK-ALBS 127K	BH-ALBS 127K	LK-ALBS 127K-FI	125	54	450	ball bearing	170	140 x 110	105 x 75–80	11	55
LK-ALBS 150K	BH-ALBS 150K	LK-ALBS 150K-FI	150	50	500	ball bearing	197	140 x 110	105 x 75–80	11	60
LK-ALBS 160K	BH-ALBS 160K	LK-ALBS 160K-FI	160	50	580	ball bearing	202	140 x 110	105 x 75–80	11	60
LK-ALBS 180K	BH-ALBS 180K	LK-ALBS 180K-FI	180	50	600	ball bearing	223	140 x 110	105 x 75–80	11	65
LK-ALBS 200K	BH-ALBS 200K	LK-ALBS 200K-FI	200	50	600	ball bearing	245	140 x 110	105 x 75–80	11	62

Versions / options



	with extremely crowned tread	with "stop-top" brake	with "central-stop" central brake system	with "ideal-stop" brake total height +17 mm	with directional lock (separate) 1x 360°	with steel foot guard
Technical description page	55	112	113	112	115	116
Product code suffix	-CO	-ST	-CS11	-IS	see **	-FS
Available for	wheel Ø 125x40, 160, 200 mm, others upon request	all	wheel Ø 100–125x40 mm	Ø 100, 125, 160, 200 with plate 140x110*	for wheel Ø and plate dimensions, see**	upon request

* Synthetic adapter plate to balance out total height for swivel and fixed castors without "ideal-stop" brake: **product code AP3-17**

** **RI-05.01** for wheel Ø 80–125 mm with plate 100x85 mm, **RI-03.03** for wheel Ø 100–125x40 mm with plate 140x110 mm, **RI-05.03** for wheel Ø 125x54–200 mm (Only for swivel castors without brake or swivel castor with "stop-top" and "central-stop" brake upon request)

LKR-ALBS series

Pressed steel castors, heavy-duty design, with bolt hole, wheel with Blickle Besthane® Soft polyurethane tread



Blickle Besthane® Soft

230–350 kg

Bracket: LKR series

- strong pressed steel, zinc-plated, blue-passivated, Cr6-free
- double ball bearing in the swivel head
- strong central kingpin
- minimum swivel head play and smooth rolling characteristic and increased service life due to the special dynamic Blickle riveting process

Wheel: ALBS series

- tread: high-quality polyurethane elastomer Blickle Besthane® Soft, hardness 75 Shore A, colour blue, non-marking, non-staining
- wheel centre: die-cast aluminium, colour silver grey

Additional details:

- bracket series: page 92
- brakes: page 112–113
- wheel series: page 319
- bearing types: page 84–85

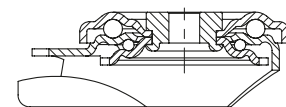

5

Swivel castors	Swivel castors with "stop-fix" brake	Wheel Ø [mm]	Wheel width [mm]	Load capacity [kg]	Bearing type	Total height [mm]	Plate Ø [mm]	Bolt hole Ø [mm]	Offset swivel castor [mm]
LKR-ALBS 82K	LKR-ALBS 82K-FI	80	40	230	ball bearing	110	88	13	40
LKR-ALBS 100K	LKR-ALBS 100K-FI	100	40	320	ball bearing	130	88	13	45
LKR-ALBS 125K	LKR-ALBS 125K-FI	125	40	350	ball bearing	155	88	13	48

Versions / options



	with extremely crowned tread	truck lock
Technical description page	55	114
Product code suffix	-CO	FF 100-1 / FF 125-1
Available for	wheel Ø 125 mm	wheel Ø 100+125 mm

LH-ALBS, BH-ALBS series

Pressed steel castors, heavy-duty design, with top plate, wheel with Blickle Besthane® Soft polyurethane tread

230–850 kg

Bracket: LH/BH series

- strong pressed steel, zinc-plated, blue-passivated, Cr6-free
- heavy fork and top plate

Swivel bracket:

- double ball bearing in the swivel head
- bolted and secured central kingpin, extremely strong
- particularly resistant to shocks and impact due to **four specially-shaped, hardened bearing seats**

Wheel: ALBS series

- tread: high-quality polyurethane elastomer Blickle Besthane® Soft, hardness 75 Shore A, colour blue, non-marking, non-staining
- wheel centre: die-cast aluminium, colour silver grey

Additional details:

- bracket series: page 92
- brakes: page 112–113
- wheel series: page 319
- bearing types: page 84–85



5

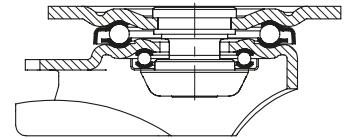

Swivel castors	Fixed castors	Swivel castors with "stop-fix" brake	Wheel Ø [mm]	Wheel width [mm]	Load capacity [kg]	Bearing type	Total height [mm]	Plate size [mm]	Bolt hole spacing [mm]	Bolt hole Ø [mm]	Offset swivel castor [mm]
LH-ALBS 82K	BH-ALBS 82K	LH-ALBS 82K-FI	80	40	230	ball bearing	120	100 x 85	80 x 60	9	45
LH-ALBS 100K-1	BH-ALBS 100K-1	LH-ALBS 100K-1-FI	100	40	320	ball bearing	140	100 x 85	80 x 60	9	45
LH-ALBS 100K-3	BH-ALBS 100K-3	LH-ALBS 100K-3-FI	100	40	320	ball bearing	140	140 x 110	105 x 75–80	11	45
LH-ALBS 125K-1	BH-ALBS 125K-1	LH-ALBS 125K-1-FI	125	40	370	ball bearing	165	100 x 85	80 x 60	9	45
LH-ALBS 125K-3	BH-ALBS 125K-3	LH-ALBS 125K-3-FI	125	40	370	ball bearing	165	140 x 110	105 x 75–80	11	45
LH-ALBS 127K	BH-ALBS 127K	LH-ALBS 127K-FI	125	54	450	ball bearing	170	140 x 110	105 x 75–80	11	55
LH-ALBS 150K	BH-ALBS 150K	LH-ALBS 150K-FI	150	50	500	ball bearing	197	140 x 110	105 x 75–80	11	65
LH-ALBS 160K	BH-ALBS 160K	LH-ALBS 160K-FI	160	50	580	ball bearing	202	140 x 110	105 x 75–80	11	65
LH-ALBS 180K	BH-ALBS 180K	LH-ALBS 180K-FI	180	50	670	ball bearing	223	140 x 110	105 x 75–80	11	67
LH-ALBS 200K	BH-ALBS 200K	LH-ALBS 200K-FI	200	50	750	ball bearing	245	140 x 110	105 x 75–80	11	70
LH-ALBS 250K	BH-ALBS 250K	*	250	50	850	ball bearing	295	140 x 110	105 x 75–80	11	82

* "stop-top" brake version, see versions / options

Versions / options



	with extremely crowned tread	with "stop-top" brake	with "central-stop" central brake system	with "ideal-stop" brake total height +17 mm	with directional lock (separate) 1x 360°	with steel foot guard
Technical description page	55	112	113	112	115	116
Product code suffix	-CO	-ST	-CS13	-IS	see ***	-FS
Available for	wheel Ø 125x40, 160, 200 mm	all	wheel Ø 160+200 mm	wheel Ø 160+200 mm**	for wheel Ø and plate dimensions, see***	wheel Ø 100–250 mm

** Synthetic adapter plate to balance out total height for swivel and fixed castors without "ideal-stop" brake: **product code AP3-17**

*** **RI-04.01** for wheel Ø 80–125 mm with plate 100x85 mm, **RI-04.03** for wheel Ø 100–125x40 mm with plate 140x110 mm, **RI-05.03** for wheel Ø 125x54–200 mm (Only for swivel castors without brake or swivel castor with "stop-top" and "central-stop" brake upon request)

LUH-ALBS, BH-ALBS series

Pressed steel castors, heavy-duty design, enclosed, with top plate, wheel with Blickle Besthane® Soft polyurethane tread



450–750 kg

Bracket: LUH/BH series

- strong pressed steel, zinc-plated, blue-passivated, Cr6-free

Swivel bracket:

- four-point ball bearing for extremely heavy loads
- enclosed and sealed swivel head
- particularly resistant to shocks and impact due to **specially-shaped, hardened bearing seats**

Wheel: ALBS series

- tread: high-quality polyurethane elastomer Blickle Besthane® Soft, hardness 75 Shore A, colour blue, non-marking, non-staining
- wheel centre: die-cast aluminium, colour silver grey

Additional details:

- bracket series: page 93
- brakes: page 112–113
- wheel series: page 319
- bearing types: page 84–85

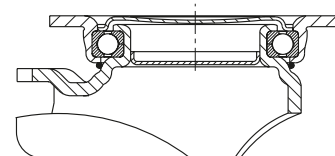

5

Swivel castors	Fixed castors	Swivel castors with "stop-fix" brake	Wheel Ø [mm]	Wheel width [mm]	Load capacity [kg]	Bearing type	Total height [mm]	Plate size [mm]	Bolt hole spacing [mm]	Bolt hole Ø [mm]	Offset swivel castor [mm]
LUH-ALBS 127K	BH-ALBS 127K	LUH-ALBS 127K-FI	125	54	450	ball bearing	170	140 x 110	105 x 75–80	11	55
LUH-ALBS 150K	BH-ALBS 150K	LUH-ALBS 150K-FI	150	50	500	ball bearing	197	140 x 110	105 x 75–80	11	61
LUH-ALBS 160K	BH-ALBS 160K	LUH-ALBS 160K-FI	160	50	580	ball bearing	202	140 x 110	105 x 75–80	11	61
LUH-ALBS 200K	BH-ALBS 200K	LUH-ALBS 200K-FI	200	50	750	ball bearing	245	140 x 110	105 x 75–80	11	63

Versions / options



	with extremely crowned tread	directional lock (separate) 1 x 360°	with steel foot guard
Technical description page	55	115	116
Product code suffix	-CO	RI-05.03	-FS
Available for	wheel Ø 160 + 200 mm	all*	upon request

* Only for swivel castors without brake

LS-ALBS, BS-ALBS series

Welded steel heavy-duty castors, heavy-duty swivel head, wheel with Blickle Besthane® Soft polyurethane tread

450–1,150 kg

Bracket: LS/BS series

- particularly robust welded steel construction, zinc-plated, yellow-passivated, Cr6-free

Swivel bracket:

- axial grooved ball bearing ISO 104 and tapered roller bearing ISO 355 in the swivel head
- bolted and secured welded central kingpin, extremely strong
- dust and splash-proof
- grease nipple

Wheel: ALBS series

- tread: high-quality polyurethane elastomer Blickle Besthane® Soft, hardness 75 Shore A, colour blue, non-marking, non-staining
- wheel centre: die-cast aluminium, colour silver grey

Additional details:

- bracket series: page 94
- brakes: page 112–113
- wheel series: page 319
- bearing types: page 84–85



5

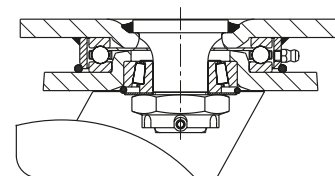

Swivel castors	Fixed castors	Swivel castor with "stop-top" brake	Wheel Ø [mm]	Wheel width [mm]	Load capacity [kg]	Bearing type	Total height [mm]	Plate size [mm]	Bolt hole spacing [mm]	Bolt hole Ø [mm]	Offset swivel castor [mm]
LS-ALBS 127K	BS-ALBS 127K	LS-ALBS 127K-ST	125	54	450	ball bearing	170	140 x 110	105 x 75–80	11	50
LS-ALBS 150K	BS-ALBS 150K	LS-ALBS 150K-ST	150	50	500	ball bearing	200	140 x 110	105 x 75–80	11	55
LS-ALBS 160K	BS-ALBS 160K	LS-ALBS 160K-ST	160	50	580	ball bearing	205	140 x 110	105 x 75–80	11	55
LS-ALBS 200K	BS-ALBS 200K	LS-ALBS 200K-ST	200	50	750	ball bearing	245	140 x 110	105 x 75–80	11	60
LS-ALBS 250K	BS-ALBS 250K	LS-ALBS 250K-ST	250	50	850	ball bearing	305	175 x 140	140 x 105	14	75
LS-ALBS 300K	BS-ALBS 300K	LS-ALBS 300K-ST	300	60	1,150	ball bearing	355	175 x 140	140 x 105	14	85

Versions / options

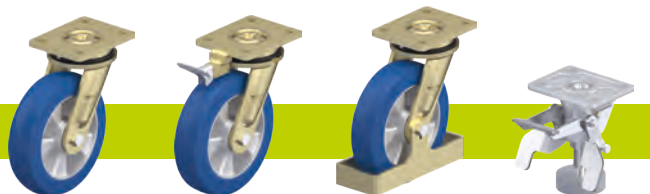

	with extremely crowned tread	with directional lock 4 x 90°	with steel foot guard	truck lock
Technical description page	55	115	116	114
Product code suffix	-CO	-RI4	-FS	FF 125 / 150 / 160 / 200
Available for	wheel Ø 160–200 mm	all	wheel Ø 125–250 mm	wheel Ø 125–200 mm

LHD-ALBS, BOD-ALBS series

Pressed steel twin wheel castors, heavy-duty design, with top plate, wheels with Blickle Besthane® Soft polyurethane tread



360–800 kg

Bracket: LHD/BOD series

- strong pressed steel, zinc-plated, blue-passivated, Cr6-free (fixed bracket: solid welded steel construction)
- heavy fork and top plate

Swivel bracket:

- double ball bearing in the swivel head
- bolted and secured central kingpin, extremely strong
- particularly resistant to shocks and impact due to **four specially-shaped, hardened bearing seats**

Wheel: ALBS series

- tread: high-quality polyurethane elastomer Blickle Besthane® Soft, hardness 75 Shore A, colour blue, non-marking, non-staining
- wheel centre: die-cast aluminium, colour silver grey

Additional details:

- bracket series: page 93
- wheel series: page 319
- bearing types: page 84–85

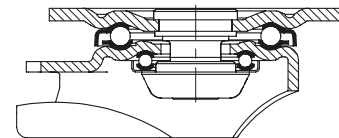

5

Swivel castors	Fixed castors	Wheel Ø [mm]	Wheel width [mm]	Load capacity [kg]	Bearing type	Total height [mm]	Plate size [mm]	Bolt hole spacing [mm]	Bolt hole Ø [mm]	Offset swivel castor [mm]
LHD-ALBS 80K		80	2 x 30	360	ball bearing	112	100 x 85	80 x 60	9	45
	BOD-ALBS 80K	80	2 x 30	400	ball bearing	115	140 x 110	105 x 75–80	11	–
LHD-ALBS 100K	BOD-ALBS 100K	100	2 x 40	640	ball bearing	145	140 x 110	105 x 75–80	11	45
LHD-ALBS 125K	BOD-ALBS 125K	125	2 x 40	740	ball bearing	170	140 x 110	105 x 75–80	11	50
LHD-ALBS 181K	BOD-ALBS 181K	180	2 x 44	800	ball bearing	235	140 x 110	105 x 75–80	11	65

Fixed castors: long side of plate parallel to the wheel axle

Versions / options



	truck lock
Technical description page	114
Product code suffix	FF 100-1 / FF 125-1
Available for	wheel Ø 100+125 mm

GVU series

**Heavy-duty wheels
with Vulkollan® tread,
with cast iron wheel centre**

450–3,000 kg

Tread and tyre hardness

92 Shore A

Smooth operation / floor preservation

good

Rolling resistance

very good

Wear resistance

excellent



5

Tread:

- high-quality polyurethane elastomer Vulkollan®, hardness 92 Shore A
- low rolling resistance
- **high dynamic load capacity**
- high abrasion resistance
- high cut and tear propagation resistance
- colour natural, non-marking, non-staining
- excellent chemical connection with the wheel centre

Wheel centre:

- rugged grey cast iron
- with grease nipple from wheel Ø 150 mm
- lacquered, colour silver

Other features:

- high chemical resistance to many aggressive substances
- operating temperature: -20 °C to +70 °C, temporarily up to +90 °C, reduced load capacity over +40 °C

Additional details:

- wheel series: page 68
- tread: page 56
- bearing types: page 84–85
- chemical resistance: page 51

Wheels	Wheel Ø (D) [mm]	Wheel width (T2) [mm]	Load capacity at 4 km/h [kg]	Load capacity at 10 km/h [kg]	Load capacity at 16 km/h [kg]	Bearing type	Axle bore Ø (d) [mm]	Hub length (T1) [mm]
GVU 100/15K	100	40	450	–	–	ball bearing	15	40
GVU 125/15K	125	40	550	–	–	ball bearing	15	45
GVU 127/20K	125	50	700	490	280	ball bearing	20	60
GVU 140/20K	140	54	900	630	360	ball bearing	20	60
GVU 150/20K	150	50	800	560	320	ball bearing	20	60
GVU 160/20K	160	50	800	560	320	ball bearing	20	60
GVU 200/20K	200	50	1,000	700	400	ball bearing	20	60
GVU 200/25K	200	50	1,000	700	400	ball bearing	25	60
GVU 202/25K	200	80	1,600	1,150	640	ball bearing	25	90
GVU 202/35K	200	80	1,600	1,150	640	ball bearing	35	90
GVU 250/25K	250	60	1,250	870	500	ball bearing	25	70
GVU 250/35K	250	60	1,250	870	500	ball bearing	35	70
GVU 252/25K	250	80	1,800	1,250	720	ball bearing	25	90
GVU 252/30K	250	80	2,200	1,500	880	ball bearing	30	90
GVU 302/30K	300	80	2,400	1,650	960	ball bearing	30	90
GVU 302/35K	300	80	2,400	1,650	960	ball bearing	35	90
GVU 304/35K	300	100	3,000	2,100	1,200	ball bearing	35	120
GVU 402/40K	400	80	3,000	2,100	1,200	ball bearing	40	90

Versions / options

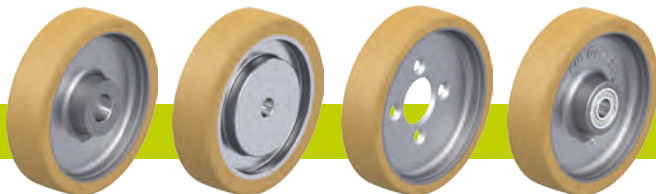

	drive wheels with hub keyway	basic wheels with steel wheel centre and hole	hub fitting wheels	other shore hardnesses
Technical description page	76	78		
Product code suffix	GVUN series	VSVU series	GVUA series	
Available for	see page 546	see page 553	upon request	upon request

